



Most Widely Accepted and Trusted

ICC-ES Report

ICC-ES | (800) 423-6587 | (562) 699-0543 | www.icc-es.org

ESR-1365

Reissued 04/2017
This report is subject to renewal 04/2018.

DIVISION: 06 00 00—WOOD, PLASTICS AND COMPOSITES
SECTION: 06 05 83—SHOP-APPLIED WOOD COATINGS
SECTION: 06 16 00—SHEATHING

REPORT HOLDER:

BARRIER TECHNOLOGY CORPORATION

510 4TH STREET NORTH
WATKINS, MINNESOTA 55389

EVALUATION SUBJECT:

**BLAZEGUARD® FIRE-RATED SHEATHING AND
BLAZEGUARD® FR DECK PANELS**



Look for the trusted marks of Conformity!

“2014 Recipient of Prestigious Western States Seismic Policy Council (WSSPC) Award in Excellence”



A Subsidiary of  **INTERNATIONAL CODE COUNCIL™**

ICC-ES Evaluation Reports are not to be construed as representing aesthetics or any other attributes not specifically addressed, nor are they to be construed as an endorsement of the subject of the report or a recommendation for its use. There is no warranty by ICC Evaluation Service, LLC, express or implied, as to any finding or other matter in this report, or as to any product covered by the report.



ICC-ES Evaluation Report

ESR-1365

Reissued April 2017

This report is subject to renewal April 2018.

www.icc-es.org | (800) 423-6587 | (562) 699-0543

A Subsidiary of the International Code Council®

DIVISION: 06 00 00—WOOD, PLASTICS AND COMPOSITES
Section: 06 05 83—Shop-Applied Wood Coatings
Section: 06 16 00—Sheathing

REPORT HOLDER:

BARRIER TECHNOLOGY CORPORATION
510 4TH STREET NORTH
WATKINS, MINNESOTA 55389
(320) 764-5797
www.intlbarrier.com

EVALUATION SUBJECT:

BLAZEGUARD® FIRE-RATED SHEATHING AND BLAZEGUARD® FR DECK PANELS

ADDITIONAL LISTEE:

LOUISIANA-PACIFIC CORPORATION
414 UNION STREET, SUITE 2000
NASHVILLE, TENNESSEE 37219
PRODUCT NAME: LP® FLAMEBLOCK® FIRE-RATED OSB SHEATHING

1.0 EVALUATION SCOPE

Compliance with the following codes:

- 2015, 2012 and 2009 *International Building Code*® (IBC)
- 2015, 2012 and 2009 *International Residential Code*® (IRC)
- 2013 *Abu Dhabi International Building Code* (ADIBC)[†]

[†]The ADIBC is based on the 2009 IBC. 2009 IBC code sections referenced in this report are the same sections in the ADIBC.

Properties evaluated:

- Surface-burning characteristics
- Durability
- Thermal barrier
- Component of fire-resistance-rated assemblies
- Component of roof covering classified assemblies

2.0 USES

Blazeguard® Fire-Rated Sheathing or LP® FlameBlock® Fire-Rated OSB Sheathing is used as a roof sheathing, a wall sheathing, an interior finish, a thermal barrier and a component of a fire-resistance-rated assembly.

Blazeguard® FR Deck Panel is used as a component of a fire-classified roof covering assembly.

3.0 DESCRIPTION

3.1 General:

The product is a composite panel consisting of a layer of Pyrotite—a noncombustible inert, inorganic fire-shield—factory-applied to either plywood or oriented strand board (OSB) complying, respectively, with US DOC PS1 or US DOC PS2. Pyrotite is applied to one or both faces of the plywood or OSB, either adhesively, mechanically or through direct application, as described in Section 3.2.

The panels are available in sizes from 4 feet by 8 feet (1219 mm by 2438 mm) up to 8 feet by 24 feet (2438 mm by 7315 mm), and in nominal thicknesses of ³/₈ inch (9.5 mm), ⁷/₁₆ inch (11.11 mm), ¹⁵/₃₂ inch (12 mm), ¹/₂ inch (12.7 mm), ⁵/₈ inch (15.9 mm) and ³/₄ inch (19 mm).

3.2 Methods of Applying Fire Shield:

3.2.1 Adhesive Method: A laminate of the appropriate thickness (see product descriptions in Section 3.3) is produced by applying a combination of Pyrotite slurry and fiberglass mat over a sheet of mylar plastic. The fiberglass mat must have a minimum tensile strength in the MD of 30 psi (206 kPa), and a minimum basis weight of 1.6 pounds per 100 square feet (0.73 kg per 9.29 m²) for 0.045-inch (1.1 mm) Pyrotite thickness and 1.80 pounds per 100 square feet (0.82 kg per 9.29 m²) for 0.060-inch (1.5 mm) Pyrotite thickness. The material is rolled with an aluminum fiberglass roller sized to ensure appropriate thickness and penetration of the fiberglass. The slurry/fiberglass mixture is then heated and allowed to cure into a hardened laminate. The laminate, once cured, is separated from the plastic sheet and trimmed to size.

The adhesive, Isoset® WD3-A322 crosslinked with CX-47, manufactured by Ashland Specialty Chemical Company is roller- or spray-applied to the surface of a selected substrate material following the guidelines and instructions of the adhesive manufacturer. The cured and trimmed Pyrotite laminate is then placed over the substrate material and placed in a press for a predetermined temperature and pressure (the temperature/pressure formula will vary slightly based on the approved adhesive) until the adhesive is appropriately hardened.

3.2.2 Mechanically Applied Method: A laminate is prepared as described in Section 3.2.1. The cured and trimmed Pyrotite laminate is placed over the substrate material and attached by mechanically nailing or stapling through the Pyrotite laminate into the substrate with

$\frac{3}{8}$ -inch (9.53 mm) staples or nails. Care is taken to ensure the staples or nails do not protrude through the opposite side of the substrate. The nails/staples are spaced a maximum of every 6 inches (152.4 mm) along the perimeter of the panel and at a maximum of every 12 inches (304.8 mm) over the entire field of the panel.

3.2.3 Direct Application: The Pyrotite material is applied by spray application or by applying the Pyrotite slurry through other means (e.g., roll coating or curtain coating) upon the surface of an approved substrate. The Pyrotite slurry is allowed to cure prior to stacking. Excess material is trimmed from the panel edges. The thickness is determined by selected substrate and product type (see Section 3.3).

3.3 Product Numbers, Names and Descriptions:

3.3.1 15382-1: Blazeguard® Fire-Rated Sheathing—Adhesively or Mechanically Applied on Plywood: A fire-rated sheathing panel with a minimum Pyrotite thickness of 0.045 inch (1.1 mm), applied by adhesive or mechanical process to a minimum $\frac{3}{8}$ -inch-thick (9.5 mm) plywood substrate. The finished panel has a minimum average coating weight of 0.57 lb/ft² (2.78 kg/m²).

3.3.2 15382-2: Blazeguard® Fire-Rated Sheathing—Adhesively or Mechanically Applied on Oriented Strand Board (OSB): A fire-rated sheathing panel with a minimum Pyrotite thickness of 0.060 inch (1.5 mm) applied by adhesive or mechanical process to a minimum nominally $\frac{3}{8}$ -inch-thick (9.5 mm) OSB substrate. The finished panel has a minimum average coating weight of 0.60 lb/ft² (2.93 kg/m²).

3.3.3 15382-3: Blazeguard® Fire-Rated Sheathing—Directly Applied on Plywood: A fire-rated sheathing panel with a minimum Pyrotite thickness of 0.045 inch (1.1 mm) applied by direct process to a minimum $\frac{3}{8}$ -inch-thick (9.5 mm) plywood substrate. The finished panel has a minimum average coating weight of 0.57 lb/ft² (2.78 kg/m²).

3.3.4 15382-4: Blazeguard® Fire-Rated Sheathing—Directly Applied on Oriented Strand Board (OSB): A fire-rated sheathing panel with a minimum Pyrotite thickness of 0.060 inch (1.5 mm) applied by direct process to a minimum nominally $\frac{3}{8}$ -inch-thick (9.5 mm) OSB substrate. The finished panel has a minimum average coating weight of 0.60 lb/ft² (2.93 kg/m²). The sheathing is also marketed under the product name LP® FlameBlock™ Fire-Rated OSB Sheathing. See Section 3.3.7.

3.3.5 15382-5: Blazeguard® FR Deck Panel A—Directly Applied on Plywood or Oriented Strand Board (OSB): A fire-rated sheathing panel with a minimum Pyrotite thickness of 0.080 inch (2.03 mm) directly applied to a minimum nominally $\frac{15}{32}$ -inch-thick (11.91 mm) plywood or a minimum nominally $\frac{7}{16}$ -inch-thick (11.11 mm) OSB substrate. The minimum average coating weight of the finished panel is 0.66 lb/ft² (3.22 kg/m²). The edges are coated with Blazeguard® Fire-retardant Paint.

3.3.6 15382-6: Blazeguard® FR Deck Panel C—Directly Applied on Plywood or Oriented Strand Board (OSB): A fire-rated sheathing panel with a minimum Pyrotite thickness of 0.04 inch (1.02 mm) directly applied to a minimum nominally $\frac{15}{32}$ -inch-thick (11.91 mm) plywood or nominally $\frac{7}{16}$ -inch-thick (11.11 mm) OSB substrate. The minimum average coating weight of the finished panel is 0.22 lb/ft² (1.07 kg/m²).

3.3.7 15382-7: LP® FlameBlock™ Fire-Rated OSB Sheathing—Directly Applied on Oriented Strand Board (OSB): A fire-rated sheathing panel with a minimum Pyrotite thickness of 0.060 inch (1.5 mm) applied by direct

process to a minimum nominally $\frac{3}{8}$ -inch-thick (9.5 mm) OSB substrate. The finished panel has a minimum average coating weight of 0.60 lb/ft² (2.93 kg/m²).

4.0 INSTALLATION

4.1 General:

The panels must be installed in accordance with the manufacturer's published literature and the requirements for wood structural panels in Chapter 23 of the IBC, or Sections R604 and R803.2 of the IRC.

The manufacturer's published installation instructions and this report must be strictly adhered to, and a copy of the instructions must be available at all times on the jobsite during installation.

If there are any conflicts between the manufacturer's instructions and this report, this report governs.

4.2 Applications:

The panels must be installed in the following applications:

- a) Roof sheathing on buildings of Type III, IV and V construction for a distance of 4 feet (1220 mm) on both sides of a fire wall to provide continuity [IBC Section 706.6, Exception 4.3, and IRC Section R302.2.2(2) Exception]. The panels must be installed with the Pyrotite laminate facing the interior of the building.
- b) Exterior walls and roof sheathing on buildings of Type I and II construction, as described in 2012 IBC Section 603.1, Subsections 1.2 and 1.3 and 2009 IBC Sections 603.1 (25.2 and 25.3). The Pyrotite laminate must be laminated to both sides of the panels.
- c) Wall sheathing for exterior walls in buildings of Type III construction with a two-hour rating or less. The inorganic fire shield must be laminated to each side of the panels and the studs must be of noncombustible material or fire-retardant-tread wood.
- d) Class A interior finish material for walls and ceilings of Type V construction (IBC Section 803). The panels must be installed with the Pyrotite laminate facing the interior of the building.
- e) Thermal barrier for separating foam plastic insulation from the interior of a building (IBC Section 2603.4). The panels must be installed with the Pyrotite laminate facing the interior of the building.
- f) Component of fire-resistance-rated construction (IBC Section 703). Refer to assemblies described in Section 4.3 of this report for orientation of the Pyrotite laminate.
- g) Component of fire-classified roof covering assemblies (IBC Section 1505.1). Refer to Section 4.4 of this report for installation details and orientation of the Pyrotite laminate faced Blazeguard® FR Deck Panels A and C.

4.3 Fire-resistance-rated Wall Assemblies:

4.3.1 One-hour Exterior Wall Assembly—Wood Stud Limited Load Bearing Wall—Interior Fire Exposure:

The wall assembly must be constructed of nominally 2-inch-by-4-inch wood studs spaced 16 inches (406 mm) on center, with two top plates and one bottom plate. The interior fire side of the wall must be covered with one layer of $\frac{5}{8}$ -inch-thick (15.88 mm), 4-foot-wide (1.2 m), Type X gypsum wallboard, applied vertically with horizontal joints blocked, and fastened with 6d, cement-coated, $\frac{1}{8}$ -inch-long (47.63 mm), cup-head drywall nails with 0.0915-inch

(2.32 mm) shank diameters and $1/4$ -inch (6.35 mm) head diameters, spaced 7 inches (178mm) on center along all studs and plates. The exposed fastener heads and wallboard joints shall be treated with two layers of gypsum compound. A minimum 2-inch-wide (51 mm) paper, plastic or fiberglass tape must be embedded in the first layer of compound over wallboard joints. Stud cavities must be filled with unfaced mineral fiber batt insulation, nominally $3\frac{1}{2}$ inches (88.9 mm) thick and with a 3 pcf (48 kg/m³) nominal density, friction-fit between studs, cross-bracing, and top and bottom plates. The exterior face of the wall must be a single layer of Blazeguard® Fire-Rated Sheathing of nominally $1/2$ -inch-thick (12.7 mm) plywood or OSB, APA performance rated $15/32$ plywood or $7/16$ OSB, with a 0.060-inch-thick (1.52 mm) Pyrotite laminate applied to only one face of the wood panel, or must be a single layer of LP® FlameBlock® Fire-Rated OSB Sheathing of nominally $7/16$ -inch-thick (11.11 mm) OSB, with a 0.060-inch-thick (1.5 mm) Pyrotite laminate applied to only one face of the wood panel. The sheathing must be installed vertically and with the Pyrotite laminate facing the wall cavity, and must be attached to the studs with $1\frac{7}{8}$ -inch-long (47.63 mm), 6d common nails, spaced 6 inches (152 mm) on center around the perimeter of the sheathing and 12 inches (304.8 mm) on center in the field.

The wall must have a fire separation distance of greater than 10 feet (3048 mm).

The design axial compressive stresses for the wood stud must be calculated in accordance with Sections 3.6 and 3.7 of ANSI/AWC/AF&PA *National Design Specification® for Wood Construction* (NDS) and must be limited to the least of the following:

- 387 psi.
- $0.95 F'_c$.
- $0.95 F'_c$, where F'_c is calculated assuming a slenderness ratio of 33.

4.3.2 Two-hour Exterior Wall Assembly—Wood Stud Limited Load Bearing Wall (Optional Steel Stud)—Interior Fire Exposure: The wall assembly must be constructed of nominally 2-inch-by-4-inch wood studs spaced 16 inches (406 mm) on center, with two top plates and one bottom plate. The interior fire side of the wall must be covered with two layers of $5/8$ -inch-thick (15.9 mm), 4-foot-wide (1.2 m), Type X gypsum wallboard, applied vertically. Horizontal joints of the inner layer of wallboard must be blocked unless horizontal joints of the adjacent wallboard layers are staggered a minimum of 12 inches (305 mm). The inner layer of wallboard must be fastened with 6d, cement-coated, $1\frac{7}{8}$ -inch-long (47.63 mm), cup-head drywall nails with 0.0915-inch (2.32 mm) shank diameters and $1/4$ -inch (6.35 mm) head diameters, spaced 6 inches (152 mm) on center along all studs and plates. The outer layer of wallboard must be installed vertically with joints staggered a minimum of 16 inches (406 mm), and fastened with 8d, cement-coated, $2\frac{3}{8}$ -inch-long (60.33 mm), cup-head drywall nails with 0.113-inch (2.87 mm) shank diameters and $9/32$ -inch (7.14 mm) head diameters, spaced 8 inches (203.2 mm) on center along studs and plates. The face layer of the wallboard must have the exposed fastener heads and board joints treated with two layers of gypsum compound. A minimum 2-inch-wide (51 mm) paper, plastic or fiberglass tape must be embedded in the first layer of compound over wallboard joints. Stud cavities must be filled with unfaced mineral fiber batt insulation, nominally $3\frac{1}{2}$ inches (89 mm) thick and with a 3 pcf (48 kg/m³) nominal density, friction-fit between studs, cross-bracing, and top and bottom plates.

In lieu of mineral fiber insulation, glass fiber insulation is permitted for use in wood framed walls. Faced or unfaced glass fiber batts $3\frac{1}{2}$ inches (89 mm) thick, nominal 0.25 pcf (4 kg/m³) nominal density are friction-fit into the wall cavity. The insulation may be applied in multiple layers to achieve thickness. The exterior face of the wall must be a single layer of Blazeguard® Fire-Rated Sheathing of nominally $1/2$ -inch-thick (12.7 mm) plywood or OSB, APA performance rated $15/32$ plywood or $7/16$ OSB, with a 0.060-inch-thick (1.52 mm) Pyrotite laminate applied to both faces of the wood panel, or must be a single layer of LP® FlameBlock® Fire-Rated OSB Sheathing of nominally $7/16$ -inch-thick (11.11 mm) OSB, with a 0.060-inch-thick (1.5 mm) Pyrotite laminate applied to both faces of the wood panel. The sheathing must be installed vertically, and attached to the studs with $1\frac{7}{8}$ -inch-long (47.63 mm), 6d common nails, spaced 6 inches (152 mm) on center around the perimeter of the sheathing and 12 inches (305 mm) on center in the field.

The wall must have a fire separation distance of greater than 10 feet (3048 mm).

The design axial compressive stresses for the wood stud must be calculated in accordance with Sections 3.6 and 3.7 of ANSI/AWC/AF&PA NDS and must be limited to the least of the following:

- 387 psi.
- $0.95 F'_c$.
- $0.95 F'_c$, where F'_c is calculated assuming a slenderness ratio of 33.

Optional:

Wood Studs Nominal 2-inch-by-6-inch with Glass Fiber Insulation:

Nominal 2-inch-by-6-inch, wood studs spaced 24 inches (610 mm) on center, with two nominal 2-inch-by-6-inch wood top plates and one nominal 2-inch-by-6-inch wood bottom plates. Stud cavities must be filled with unfaced glass fiber batt insulation, nominally $5\frac{1}{2}$ inches (140 mm) thick and with a 0.25 pcf (4 kg/m³) nominal density, friction-fit between studs, cross-bracing, and top and bottom plates. The insulation may be applied in multiple layers to achieve thickness.

Steel Studs:

In lieu of wood studs, corrosion protected steel studs, minimum No. 20 MSG and minimum $3\frac{1}{2}$ inch (89 mm) deep, cold formed and designed in accordance with AISI Specifications for steel studs. The maximum stud spacing is 16 inches (406 mm) on center. Studs are attached to floor and ceiling steel tracks with $1\frac{1}{2}$ inch long Type S-12 steel screws on both sides of the studs or by welded or bolted connections in accordance with AISI specifications. Design calculations and details of the steel stud framed wall must be submitted to the local code official.

4.3.3 Two-hour Assembly—Wood Stud Limited Load Bearing Fire-resistance-rated—Interior Party Wall:

The wall assembly is a double-framed wall consisting of two identical stud walls with a space of 1 inch (25.4 mm) separating them. The walls must be constructed of nominally 2-inch-by-4-inch, wood studs spaced 16 inches (406 mm) on center, with two 2-by-4 top plates and one 2-by-4 bottom plate. Both outside faces of the wall Configuration A (refer to Figure 3) or both inside faces of the wall Configuration B (refer to Figure 3) must be covered with a layer of Blazeguard® Fire-Rated Sheathing of nominally $1/2$ -inch-thick (12.7 mm) plywood or OSB, APA performance rated $15/32$ plywood or $7/16$ OSB, with a

0.060-inch-thick (1.52 mm) Pyrotite laminate applied to only one face of the wood panel, or with an inner layer of LP® FlameBlock® Fire-Rated OSB Sheathing of nominally $\frac{7}{16}$ -inch-thick (11.11 mm) OSB, with a 0.060-inch-thick (1.5 mm) Pyrotite laminate applied to only one face of the wood panel. The sheathing is installed vertically with the Pyrotite laminate facing the wall cavity, and attached to the studs with $\frac{1}{8}$ -inch-long (47.6 mm), 6d common nails, spaced 6 inches (152 mm) on center around the perimeter of the sheathing and 12 inches (305 mm) on center in the field. Both faces of the assembly must be covered with an outer layer of $\frac{5}{8}$ -inch-thick (15.88 mm), 4-foot-wide (1.2 m), Type X gypsum wallboard, applied vertically with joints staggered a minimum of 16 inches (406 mm) from the Pyrotite laminate sheathing and fastened with 8d, cement-coated, $\frac{2}{8}$ -inch-long (60.33 mm), cup-head drywall nails with 0.113-inch (2.87 mm) shank diameters and $\frac{9}{32}$ -inch (7.1 mm) head diameters, spaced 8 inches (203 mm) on center along studs and plates. Horizontal joints of the Blazeguard® or FlameBlock® sheathing must be blocked unless horizontal joints at the inner layer of Blazeguard® or FlameBlock® sheathing and the outer layer of gypsum wallboard (both sides of the wall) are staggered a minimum of 12 inches (305 mm). The face layer of the wallboard must have the exposed fastener heads and board joint treated with two layers of gypsum compound. A minimum 2-inch-wide (51 mm) paper, plastic or fiberglass tape must be embedded in the first layer of compound over wallboard joints. Stud cavities must be filled with faced or unfaced mineral fiber batt insulation, nominally $3\frac{1}{2}$ inches (89 mm) thick and with a 3 pcf (48 kg/m³) nominal density, or faced or unfaced glass fiber batt insulation, nominally $3\frac{1}{2}$ inches (89 mm) thick and with a 0.25 pcf (4kg/m³) nominal density, friction fit between the studs, cross-bracing, and top and bottom plates.

Optional:

Wall framing (both walls) to be nominal 2-inch-by-6-inch wood studs spaced 24 inches (610 mm) on center, with two nominal 2-inch-by-6-inch wood top plates and one 2-inch-by-6-inch wood bottom plates. Stud cavities must be filled with faced or unfaced mineral fiber batt insulation, nominally $5\frac{1}{2}$ inches (140 mm) thick and with a 3 pcf (48 kg/m³) nominal density, or faced or unfaced glass fiber batt insulation, nominally $5\frac{1}{2}$ inches (140 mm) thick and with a 0.25 pcf (4kg/m³) nominal density, friction fit between the studs, cross-bracing, and top and bottom plates." The insulation may be applied in multiple layers to achieve thickness.

Optional:

For attachment of gypsum boards in Configuration B (Refer to Figure 3), resilient channel, 25 MSG galvanized steel, spaced vertically 24 inches (610 mm) on center, flange portion screw-attached to one side of studs with $\frac{1}{4}$ -inch long diamond-shaped point, double lead, Phillips head screws.

Fire exposure may be from either side of the wall.

The design axial compressive stresses for the wood stud must be calculated in accordance with Sections 3.6 and 3.7 of ANSI/AWC/AF&PA NDS and must be limited to the least of the following:

- 387 psi.
- $0.95 F'_c$.
- $0.95 F'_c$, where F'_c is calculated assuming a slenderness ratio of 33.

4.3.4 One-hour Exterior Wall Assembly—Wood Stud Limited Load-bearing Wall: The wall assembly must be constructed of nominally 2-inch-by-6-inch, wood studs spaced 16 inches (406 mm) on center, with two top plates and one bottom plate. The interior fire side of the wall must be covered with one layer of $\frac{5}{8}$ -inch-thick (15.88 mm), 4-foot-wide (1.2 m), Type X gypsum wallboard, applied vertically with horizontal joints blocked, and fastened with 6d, cement-coated, $\frac{1}{8}$ -inch-long (47.63 mm), cup-head drywall nails with 0.0915-inch (2.32 mm) shank diameters and $\frac{1}{4}$ -inch (6.35 mm) head diameters, spaced 8 inches (178mm) on center along all studs and plates. The exposed fastener heads and wallboard joints must be treated with two coats of gypsum compound. A minimum 2-inch-wide (51 mm) paper, plastic or fiberglass tape must be embedded in the first layer of compound over wallboard joints. Stud cavities must be filled with unfaced mineral fiber batt insulation, nominally $5\frac{1}{2}$ inches (88.9 mm) thick and with a 3 pcf (48 kg/m³) nominal density, friction-fit between studs, cross-bracing, and top and bottom plates. The exterior face of the wall must be a single layer of Blazeguard® Fire-rated Sheathing of nominally $\frac{15}{32}$ -inch-thick (11.91 mm) plywood or $\frac{7}{16}$ -inch-thick (11.11 mm) OSB, with a 0.060-inch-thick (1.5 mm) Pyrotite laminate applied to only one face of the wood panel, or must be a single layer of LP® FlameBlock® Fire-Rated OSB Sheathing of nominally $\frac{7}{16}$ -inch-thick (11.11 mm) OSB, with a 0.060-inch-thick (1.5 mm) Pyrotite laminate applied to only one face of the wood panel. The sheathing must be installed vertically with horizontal joints blocked and with the Pyrotite laminate facing the outside, and must be attached to the studs with $\frac{1}{8}$ -inch-long (47.63 mm), 6d common nails, spaced 6 inches (152 mm) on center around the perimeter of the sheathing and 12 inches (304.8 mm) on center in the field.

Fire exposure may be from either side of the wall.

The design axial compressive stresses for the wood stud must be calculated in accordance with Sections 3.6 and 3.7 of ANSI/AWC/AF&PA NDS and must be limited to the least of the following:

- 204 psi.
- $0.24 F'_c$.
- $0.24 F'_c$, where F'_c is calculated assuming a slenderness ratio of 21.

4.4 Fire-classified Roof Covering Assemblies:

The following assemblies must be installed at a minimum slope of $\frac{1}{4}$:12 (2 percent) and a maximum slope of $\frac{1}{2}$:12 (4 percent).

4.4.1 Class A, Fully Adhered, Single-ply Membrane Roof Covering Assembly:

The roof deck must be product No. 15382-5, Blazeguard® FR Deck Panel A installed with the Pyrotite laminate facing the exterior (up). All deck joints must be blocked with nominally 2-by-4 lumber. Gaps in the deck panels must be caulked with Rectorseal FlameSafe FS900+ UL-classified sealant. The deck must be covered with an EPDM, TPO or PVC membranes, either 0.045 or 0.060 inch (1.14 or 1.52 mm) thick, or a self-adhered modified bitumen cap sheet. Roofing membranes must be UL-classified for roofing systems and must be recognized in a current ICC-ES evaluation report.

The EPDM, TPO or PVC membrane must be fully adhered to the deck with Mule-Hide Water-Base Bonding Adhesive, recognized in [ESR-1776](#). The adhesive must be applied at a rate of 100 square feet per gallon (2.45 m²/L).

4.4.2 Class A, Fully Adhered or Mechanically Attached, Single-ply Membrane Roof Covering Assembly: The roof deck must be product No. 15382-5, Blazeguard® FR Deck Panel A installed with the Pyrotite laminate facing the exterior (up). The deck must be covered with an EPDM or TPO membrane, either 0.045 or 0.060 inch (1.14 or 1.52 mm) thick, mechanically attached or fully adhered with an adhesive. The membrane and adhesive must be UL-classified for roofing systems. The membrane must be recognized in a current ICC-ES evaluation report. The adhesive must be applied at a rate of 100 square feet per gallon (2.45 m² per L).

4.4.3 Class C, Fully Adhered or Mechanically Attached, Singly-ply Membrane Roof Covering Assembly: The roof deck must be product No. 15382-6, Blazeguard® FR Deck Panel C installed with the Pyrotite laminate facing the exterior (up). The deck must be covered with an EPDM or TPO membrane, either 0.045 or 0.060 inch (1.14 or 1.52 mm) thick, mechanically attached or fully adhered, with an adhesive. The membrane and adhesive must be UL-classified for roofing systems. The membrane must be recognized in a current ICC-ES evaluation report. The adhesive must be applied at a rate of 100 square feet (2.45 m² per L) per gallon.

5.0 CONDITIONS OF USE

The Blazeguard® Fire-Rated Sheathing, LP® FlameBlock® Fire-Rated OSB Sheathing and Blazeguard® FR Deck Panels described in this report comply with, or are suitable alternatives to what is specified in, those codes listed in Section 1.0 of this report, subject to the following conditions:

- 5.1 The structural system is outside the scope of this report and must be designed in accordance with the IBC or the IRC.

5.2 The Blazeguard® Fire-Rated Sheathing and LP® FlameBlock® Fire-Rated OSB Sheathing must be covered with a wall covering complying with the IBC or IRC, when installed as exterior sheathing.

5.3 Use of the Blazeguard® Fire-Rated Sheathing, LP® FlameBlock® Fire-Rated OSB Sheathing and Blazeguard® FR Deck Panels for applications other than those noted in Section 4.2 of this report is outside the scope of this report.

5.4 Blazeguard® Fire-Rated Sheathing, LP® FlameBlock® Fire-Rated OSB Sheathing and Blazeguard® FR Deck Panels are manufactured by Barrier Technology Corporation, in Watkins, Minnesota, under a quality control program with inspections by ICC-ES. LP® FlameBlock® Fire-Rated OSB Sheathing is also manufactured by Louisiana-Pacific Corporation in Thomasville, Alabama with inspections by ICC-ES.

6.0 EVIDENCE SUBMITTED

Data in accordance with the ICC-ES Acceptance Criteria for Wood Structural Panels Laminated with an Inert, Inorganic Fire Shield (AC264), dated February 2012, Editorially Revised November 2016.

7.0 IDENTIFICATION

Each panel covered by this report must be identified by a stamp bearing the manufacturer's name (Barrier Technology Corporation) or the name of the additional listee (Louisiana-Pacific Corporation), the product name, the product identification number, and the evaluation report number (ESR-1365). See Figures 1 and 2 for product label samples.

Each panel must have the grade, thickness and span rating designation for the wood structural panels visible for field identification after lamination.



FIGURE 1—PRODUCT LABELS

LP FLAMEBLOCK®
BUILDING PRODUCTS FIRE-RATED OSB SHEATHING

**15/32
 CATEGORY
 FIRE-RATED
 OSB SHEATHING**

RATED SHEATHING
32/16
 SIZED FOR SPACING
 EXPOSURE 1

DESIGN LOADS AT: LPCORP.COM/FLAMEBLOCK

888-820-0325 LPCorp.com

LP FLAMEBLOCK®
BUILDING PRODUCTS FIRE-RATED OSB SHEATHING

**15/32
 CATEGORY
 FIRE-RATED
 OSB SHEATHING**

RATED SHEATHING
32/16
 SIZED FOR SPACING
 EXPOSURE 1

DESIGN LOADS AT: LPCORP.COM/FLAMEBLOCK

888-820-0325 LPCorp.com

 PERI # 6013
 Listed Roof & Wall Sheathing

 LISTED

ICC ESR 1365
Barrier Technology Corporation
 15382-7

  LISTED
 R26721-3TX1
 R21591-10ES or 24CP

 PMG-1089 

INSPECTED BY INTERTEK TS-NA, INC. (AA-690)
 AND
 UNDERWRITERS LABORATORIES, INC. (AA-668)



CONSTRUCTION SHEATHING
 1R24/2F16/W24
 11MM
 CSA 0325-07
 EXTERIOR TYPE ADHESIVE
 MANUFACTURED IN THOMASVILLE, AL



TREATED SURFACE BURNING CHARACTERISTICS
 ASTM E84/UL 723
 IN ACCORDANCE WITH IBC SECTION 2303.2
 FLAME SPREAD: 10 OR LESS
 SMOKE DEVELOPED: 5 OR LESS
 30 MINUTE TEST: PASS

 PERI # 6013
 Listed Roof & Wall Sheathing

 LISTED

ICC ESR 1365
Barrier Technology Corporation
 15382-7

  LISTED
 R26721-3TX1
 R21591-10ES or 24CP

 PMG-1089 

INSPECTED BY INTERTEK TS-NA, INC. (AA-690)
 AND
 UNDERWRITERS LABORATORIES, INC. (AA-668)

CONSTRUCTION SHEATHING
 1R24/2F16/W24
 11MM
 CSA 0325-07
 EXTERIOR TYPE ADHESIVE
 MANUFACTURED IN WATKINS, MN

TREATED SURFACE BURNING CHARACTERISTICS
 ASTM E84/UL 723
 IN ACCORDANCE WITH IBC SECTION 2303.2
 FLAME SPREAD: 10 OR LESS
 SMOKE DEVELOPED: 5 OR LESS
 30 MINUTE TEST: PASS

FIGURE 2—PRODUCT LABELS

LP® FlameBlock® manufactured in Thomasville, Alabama or Watkins, Minnesota

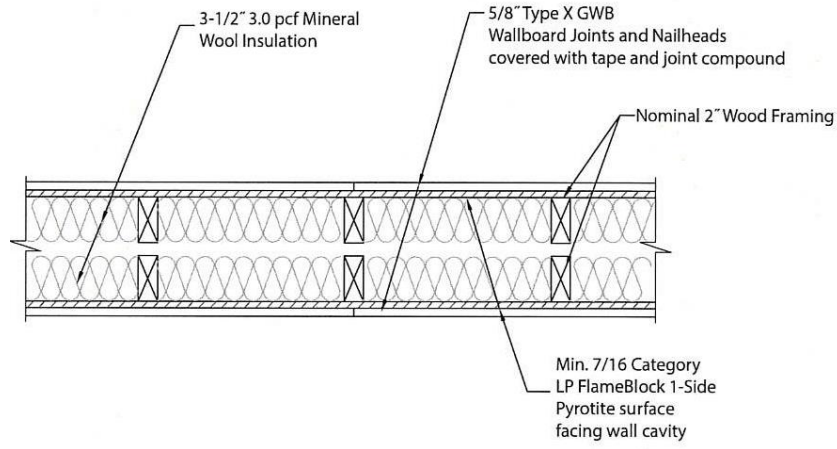

HORIZONTAL SECTION
 DESIGN No. - UL BXUV.U350
 2-HOUR INTERIOR PARTY WALL
 STC Rating = 61
 Configuration A

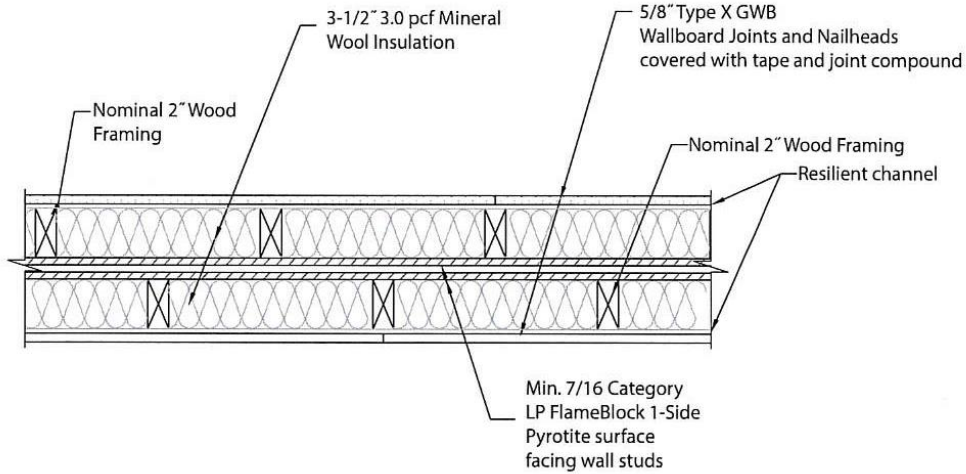

HORIZONTAL SECTION
 DESIGN No. - UL BXUV.U350
 2-HOUR INTERIOR PARTY WALL
 STC Rating = 61
 Configuration B

FIGURE 3—CONFIGURATION A AND B (REFER TO SECTION 4.3.3)