

BXUV.U350 -

Design/System/Construction/Assembly Usage Disclaimer

- Authorities Having Jurisdiction should be consulted in all cases as to the particular requirements covering the installation and use of UL Certified products, equipment, system, devices, and materials.
- Authorities Having Jurisdiction should be consulted before construction.
- Fire resistance assemblies and products are developed by the design submitter and have been investigated by UL for compliance with applicable requirements. The published information cannot always address every construction nuance encountered in the field.
- When field issues arise, it is recommended the first contact for assistance be the technical service staff provided by the product manufacturer noted for the design. Users of fire resistance assemblies are advised to consult the general Guide Information for each product category and each group of assemblies. The Guide Information includes specifics concerning alternate materials and alternate methods of construction.
- Only products which bear UL's Mark are considered Certified.

BXUV - Fire Resistance Ratings - ANSI/UL 263 Certified for
United States

BXUV7 - Fire Resistance Ratings - CAN/ULC-S101 Certified for
Canada

See General Information for Fire-resistance Ratings - ANSI/UL 263 Certified for United States
Design Criteria and Allowable Variances

See General Information for Fire Resistance Ratings - CAN/ULC-S101 Certified for Canada
Design Criteria and Allowable Variances

Design No. U350

September 10, 2019

Bearing Wall Rating — 2 Hr

Finish Rating — 23 min

STC Ratings — 61, 56 (See Items 2, 2A, 7, 7A)

This design was evaluated using a load design method other than the Limit States Design Method (e.g., Working Stress Design Method). For jurisdictions employing the Limit States Design Method, such as Canada, a load restriction factor shall be used — See Guide BXUV or BXUV7

*** Indicates such products shall bear the UL or cUL Certification Mark for jurisdictions employing the UL or cUL Certification (such as Canada), respectively.**

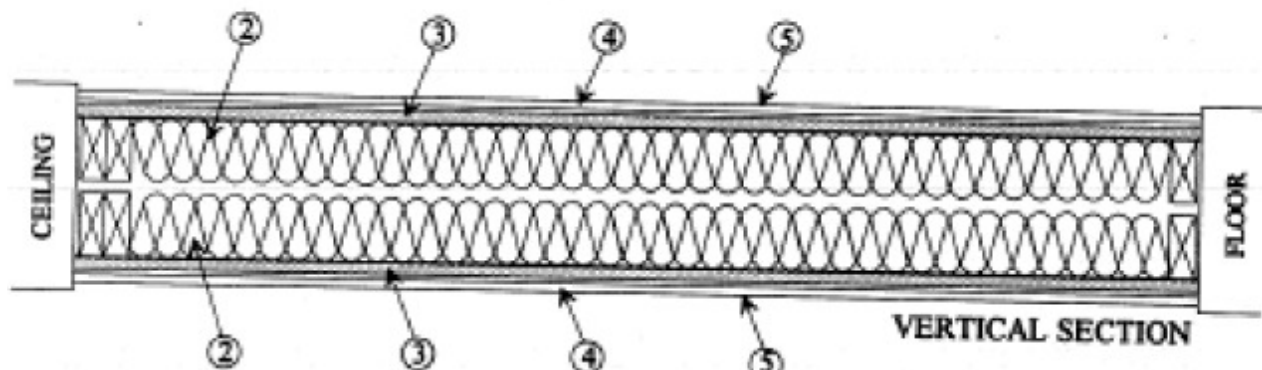
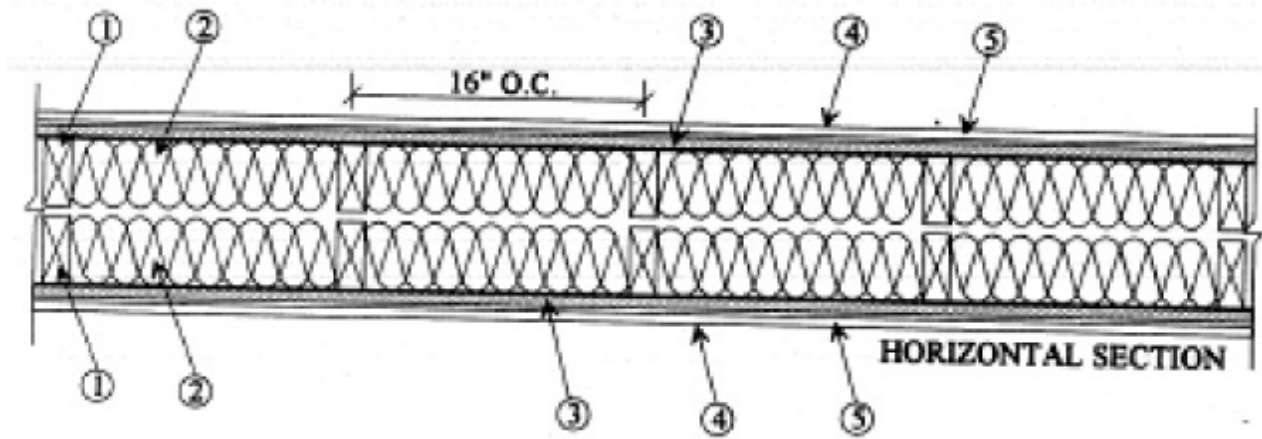

CONFIGURATION A

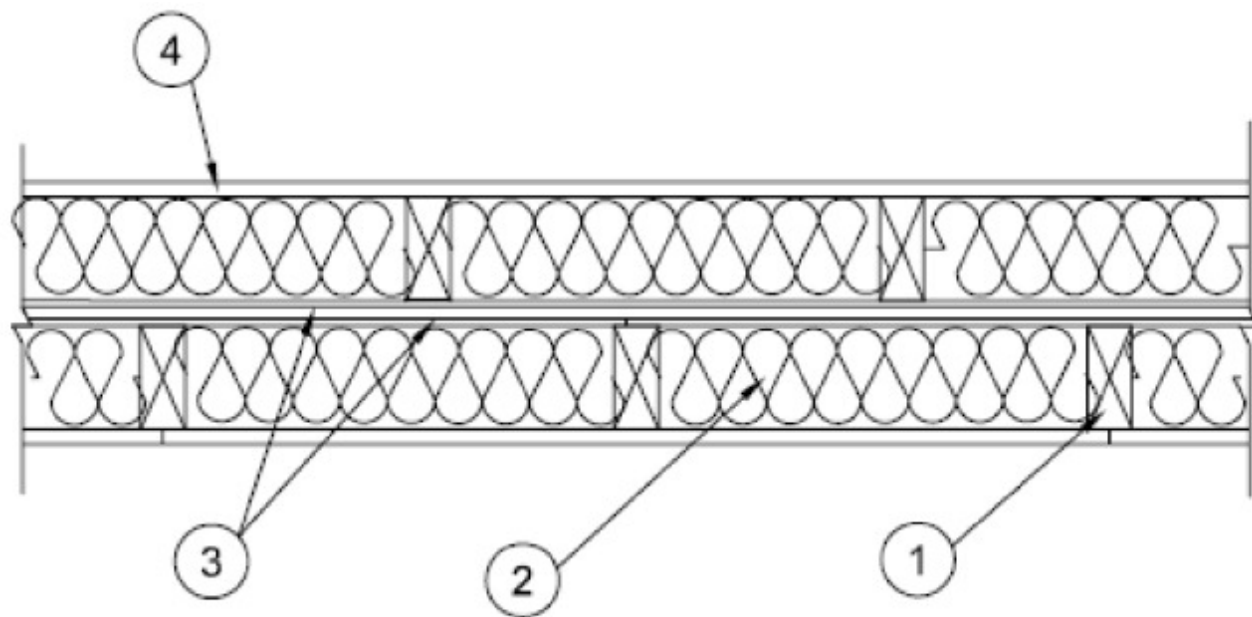

CONFIGURATION B

1. **Wood Studs** — Double row of nom 2 by 4 in., spaced 16 in. OC with two 2 by 4 top and one 2 by 4 bottom plates. As an option, nom 2 in. by 6 in., spaced 24 in. OC with two 2 in. by 6 in. top and one 2 in. by 6 in. bottom plates may be used in lieu of 2 in. by 4 in. studs and plates. Studs effectively fire stopped. Opposite stud rows spaced 1 in. apart.
2. **Batts and Blankets*** — Used to achieve the STC Ratings - Faced or unfaced mineral fiber insulation, 3-1/2 in.

thick, nom 3.0 pcf, pressure fit in the wall cavity between stud, plates, and cross bracing
See **Batts and Blankets*** (BZJZ) category for names of Classified manufacturers.

2A. **Glass Fiber Insulation** — (As an alternate to Item 2, not for use with STC Ratings) — Faced or unfaced glass fiber batts 3-1/2 in. thick, nom 0.25 pcf, pressure fit in the wall cavity between stud, plates, and cross bracing may be used. If 2 by 6 in. studs (Item 1) are used, min. 5-1/2 in. of unfaced glass fiber batts, nom 0.25 pcf, pressure fit in the wall cavity between stud, plates, and cross bracing. Insulation may be applied in multiple layers to achieve final thickness. See **Batts and Blankets*** (BZJZ) category for names of Classified manufacturers.

2B. **Loose Fill Materials** — (As an alternate to Item 2A, not for use with STC Ratings) — Blown-in fiberglass loose-fill insulation material. The insulation is applied in a dry state to completely fill the enclosed cavity with a minimum density of 0.25 pcf.

2C. **Fiber, Sprayed*** — As an alternate to Batts and Blankets (Item 2, not for use with STC Ratings) — (100% Borate Formulation) — Spray applied cellulose material. The fiber is applied with water to completely fill the enclosed cavity in accordance with the application instructions supplied with the product with a nominal dry density of 2.7 lb/ft³. Alternate Application Method: The fiber is applied without water or adhesive at a nominal dry density of 3.5 lb/ft³, in accordance with the application instructions supplied with the product.

U S GREENFIBER L L C — INS735, INS745 and INS750LD for use with wet or dry application. INS765LD and INS773LD are to be used for dry application only.

2D. **Fiber, Sprayed*** — As an alternate to Batts and Blankets (Item 2, not for use with STC Ratings) - Spray applied cellulose material. The fiber is applied with water to completely fill the enclosed cavity in accordance with the application instructions supplied with the product. The minimum dry density shall be 4.30 lbs/ft³.

INTERNATIONAL CELLULOSE CORP — Celbar-RL

2E. **Fiber, Sprayed*** — As an alternate to Batts and Blankets (Item 2, not for use with STC Ratings) — Spray applied cellulose material. The fiber is applied with water to interior surfaces in accordance with the application instructions supplied with the product. Applied to completely fill the enclosed cavity. Minimum dry density of 4.3 pounds per cubic ft.

NU-WOOL CO INC — Cellulose Insulation

3. **Building Units*** — Building units placed with the laminate face against, and nailed to the wood framing with 1-7/8 in. long, 6d nails, spaced 6 in. OC. on the perimeter and 12 in. OC. in the field.

LOUISIANA-PACIFIC CORP — Type Blazeguard 1-Side

LOUISIANA-PACIFIC CORP — Type LP FlameBlock 1-Side

4. **Gypsum Board*** — **Any 5/8 in. thick UL Classified Gypsum Board that is eligible for use in Design Nos. L501, G512 or U305.** Nom. 5/8 in. thick, 4 ft. wide board, applied vertically over building units (Item 3) or attached directly to the wood studs (Configuration B) with joints staggered from joints of building units and nailed to studs and bearing plates through the building units 8 in. OC. with 8d cement coated nails, 2-3/8 in. long, 0.113 in. shank diam. and 9/32 in. diam. head. When constructing Configuration B, 1-7/8 in. long, 8d cement coated nails spaced 8 in. OC. shall be used to fasten the gypsum board directly to the wood studs. When Item 6, resilient channels are used, gypsum panels applied vertically and screw attached with 1 in. long, self-drilling, self-tapping Type S or S-12 steel screws spaced 8 in. OC.

CABOT MANUFACTURING ULC (View Classification) — CKNX.R25370

AMERICAN GYPSUM CO (View Classification) — CKNX.R14196

BEIJING NEW BUILDING MATERIALS PUBLIC LTD CO (View Classification) — CKNX.R19374

CONTINENTAL BUILDING PRODUCTS OPERATING CO, L L C (View Classification) — CKNX.R3660

CGC INC (View Classification) — CKNX.R19751

GEORGIA-PACIFIC GYPSUM L L C (View Classification) — CKNX.R2717

CONTINENTAL BUILDING PRODUCTS OPERATING CO, L L C (View Classification) — CKNX.R18482

LOADMASTER SYSTEMS INC (View Classification) — CKNX.R11809

NATIONAL GYPSUM CO (View Classification) — CKNX.R3501

PABCO BUILDING PRODUCTS L L C, DBA PABCO GYPSUM (View Classification) — CKNX.R7094

PANEL REY S A (View Classification) — CKNX.R21796

SIAM GYPSUM INDUSTRY (SARABURI) CO LTD (View Classification) — CKNX.R19262

GEORGIA-PACIFIC GYPSUM L L C (View Classification) — CKNX.R6937

THAI GYPSUM PRODUCTS PCL (View Classification) — CKNX.R27517

UNITED STATES GYPSUM CO (View Classification) — CKNX.R1319

USG MEXICO S A DE C V (View Classification) — CKNX.R16089

5. **Joints and Nailheads** — Gypsum board joints covered with tape and joint compound. Nail heads covered with joint compound.

6. **Resilient Channel** — Optional - Not Shown - For use with gypsum boards in Configuration B, 25 MSG galv steel, spaced vertically 24 in. OC, flange portion screw attached to one side of studs with 1-1/4 in. long diamond shaped point, double lead Phillips head steel screws.

7. **STC Rating** — The STC Rating of Configuration A is 61 when it is constructed as described by Items 1 through 5, except:

A. Item 1, above - Wood Studs - Studs in opposite rows shall be staggered 8 in. OC.

B. Item 4, above - Gypsum Board - Min. weight 2.0 psf.

7A. **STC Rating** — The STC Rating of Configuration B is 56 when it is constructed as described by Items 1 through 6, except:

A. Item 1, above - Wood Studs - Studs in opposite rows shall be staggered 8 in. OC.

B. Item 4, above - Gypsum Board - Min. weight 2.0 psf.

C. Item 6, above - Resilient Channels - The gypsum board shall be attached to the studs with resilient channels.

*** Indicates such products shall bear the UL or cUL Certification Mark for jurisdictions employing the UL or cUL Certification (such as Canada), respectively.**

Last Updated on 2019-09-10

The appearance of a company's name or product in this database does not in itself assure that products so identified have been manufactured under UL's Follow-Up Service. Only those products bearing the UL Mark should be considered to be Certified and covered under UL's Follow-Up Service. Always look for the Mark on the product.

UL permits the reproduction of the material contained in the Online Certification Directory subject to the following conditions: 1. The Guide Information, Assemblies, Constructions, Designs, Systems, and/or Certifications (files) must be presented in their entirety and in a non-misleading manner, without any manipulation of the data (or drawings). 2. The statement "Reprinted from the Online Certifications Directory with permission from UL" must appear adjacent to the extracted material. In addition, the reprinted material must include a copyright notice in the following format: "© 2020 UL LLC"