



38 SERIES BRUSHED SMOOTH OR CEDAR TEXTURE PREFINISHED LAP JOINT SIDING

LOUISIANA-PACIFIC CORPORATION PERIODICALLY UPDATES AND REVISES ITS PRODUCT INFORMATION AND APPLICATION, CARE, AND MAINTENANCE INSTRUCTIONS. WARRANTY REMEDIES ARE NOT AVAILABLE IF THESE INSTRUCTIONS ARE NOT FOLLOWED. THE INFORMATION IN THIS DOCUMENT IS SUBJECT TO CHANGE WITHOUT NOTICE.

FIND ALL LP® SMARTSIDE® PRODUCT LITERATURE AT LPCORP.COM/SMARTSIDE

LP® SmartSide® Trim & Siding is covered under the LP® SmartSide® Prorated 50-Year Limited Warranty. Refer to the warranty, which is available online, for complete terms and conditions. Product must be transported, stored, handled, installed, finished, and maintained in accordance with all published application, finishing, care, and maintenance instructions, technical notes, and bulletins (collectively, "Instructions") in effect at the time of installation.

Failure to follow such Instructions will make the limited warranty inapplicable as to the products affected by such failure. No modification or exception to these Instructions and no non-published recommendations are valid unless issued in writing on a project-specific basis by LP's Director of Technology prior to application. Always check and comply with local building codes. Even where these instructions approve installation over certain substrates or incorporate requirements of building codes, LP's liability for the performance of the product is limited as expressly provided in the Limited Warranty.

⚠ WARNING: Drilling, sawing, sanding or machining wood products can expose you to wood dust, a substance known to the State of California to cause cancer. Avoid inhaling wood dust or use a dust mask or other safeguards for personal protection. For more information go to P65Warnings.ca.gov/wood-dust.

PRODUCT LEGEND

- A** LP® SmartSide® ExpertFinish® Lap Joint Siding
- B** LP® SmartSide® ExpertFinish® Panel Siding
- C** LP® SmartSide® ExpertFinish® Vertical Siding
- D** LP® SmartSide® ExpertFinish® Cedar Shake
- E** LP® SmartSide® ExpertFinish® Trim & Fascia
- F** LP® SmartSide® ExpertFinish® Soffit
- G** LP® SmartSide® ExpertFinish® Accessories
- H** LP® SmartSide® ExpertFinish® Nickel Gap Siding

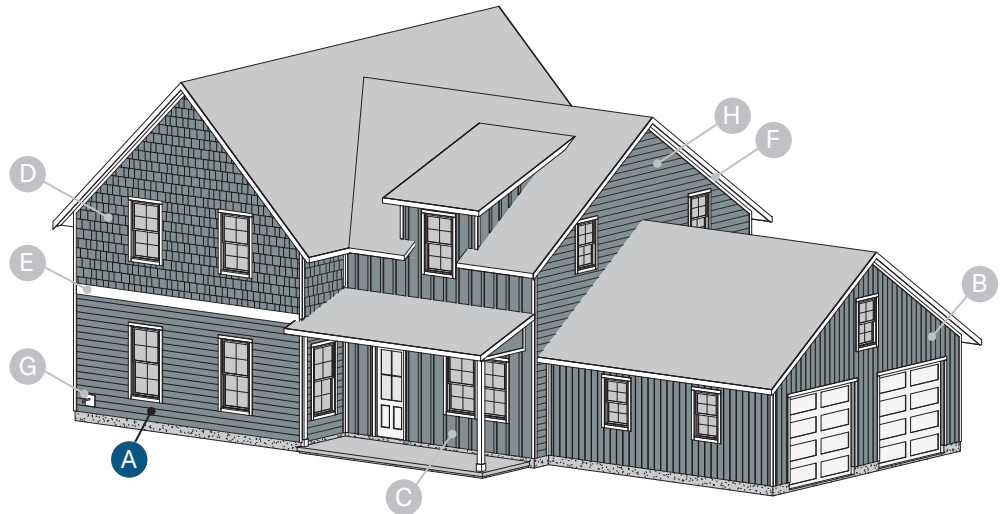

GENERAL INFORMATION

HANDLING

- Handle prefinished LP SmartSide ExpertFinish lap siding with extreme care during storage and application.
 - When unpackaging siding, cut the clear shrink-wrap the full-length of siding to avoid dragging and scuffing of the painted surface.
 - If siding is restacked after removing clear shrink-wrap, make sure to keep slip between painted surface and back of the siding.



STORAGE

- Store off the ground well supported, on a flat well-drained surface. If delivered without a pallet, additional support may be required to provide a minimum 2 inch (51 mm) clearance of Prefinished siding from the ground.
- Store Prefinished siding under a roof or separate waterproof covering until the siding is installed on the structure. **The clear shrink-wrap is perforated and does not provide protection from water intrusion.**
 - Protect the Prefinished siding at the end of each installation day by moving siding back under a roof or reapply a waterproof covering.
- Do not install if any type of residue is detected on the surface. Follow Residue Removal Guidelines in [Technical Bulletin #053](#).

GENERAL INFORMATION (CONT'D.)

BEFORE YOU BEGIN

- At the time of manufacture, siding meets or exceeds the performance standards set forth in ICC-ES AC321 and has achieved recognition under PR-N124, ESR-1301, CCMC 11826-L, FL#9109 and HUD-MR-1318d. For copies of product approvals go online at <https://lpcorp.com/product-literature> or call LP Customer Support at 888-820-0325.
- Where siding butts window trim, door casings, butt joints, etc. leave a 3/16 inch (5 mm) gap and seal.
 - Larger gap is required when siding is adjacent to stucco, brick, cultured stone, mortar, etc. (Figure 7a)
- Min. 6 inch (152 mm) clearance must be maintained between siding and finish grade (ground cover). *[Min. 200 mm (8 inch) clearance must be maintained between cladding and finish ground when installing cladding in Canada in accordance with NBC, Section 9.27.2.4.(1) or local building code requirements.]*
- Siding applied adjacent to surfaces such as porches, patios, balconies, or walking surfaces (including porch columns) must have a clearance of at least 1 inch (25 mm) above horizontal surface.
 - Clearance may be reduced to 3/8 inch (10 mm) for:
 - Porches, patios, balconies, or walking surfaces that slope away from the structure or the surface provides gaps that allow water to flow through so that it cannot accumulate, and is covered by a roof, not an eave or overhang; or
 - Porch columns with walking surfaces that slope away from the structure or the surface provides gaps that allow water to flow through so that it cannot accumulate.
- All wood substrate directly exposed to the weather must be sealed to prevent moisture intrusion and water build up.
 - Seal ALL exposed cuts of siding and trim. Field spray applied coatings on cuts are not recommended.
 - Sealing can be accomplished by applying a paint or sealant according to the manufacturer's requirements.
- See **Alternate Fastening Options** starting on page 8 for attaching lap to wood structural panel sheathing, SIP assemblies, steel studs, or ICF. Lap siding installed vertically can be found on pages 8, 9 and 10.

TRIM

- Use a min. 540 Series trim so the lap siding does not extend beyond the face of the trim.
 - If trim is installed over lap, a thinner 440 or 190 Series trim may be used.
- Lap siding is not designed to be used as trim.
 - Exception: lap joint siding may be used as fascia. Shiplap must be removed to full panel thickness. (Figure 4b)
- See page 10 for PREFERRED and ALTERNATE details for Outside and Inside Corner Trim. (Figure 10e, 10f, 10g, 10h)

FLASHING

- All openings must be properly sealed or flashed in a manner that prevents moisture intrusion or buildup.
- Flashing shall be metal or another durable material that will last for not less than 50 years.
- Install step flashing at roof-to-wall intersections with a min. 4 inch (102 mm) upper leg. (Figure 2a, 2b)
- All other flashing must have a min. 4 inch (102 mm) upper leg.
 - Add 4 inch (102 mm) wide adhesive flashing when upper leg is less than 4 inches (102 mm).
- Properly integrate flashing with WRB. Use WRB or flashing tape to maintain counterflashing principle.

ROOF TO WALL INTERSECTION

- Maintain 1 inch (25 mm) clearance between siding and roofing, or trim and roofing. *[Min. 50 mm (2 inch) clearance at intersection with roof line must be maintained between roof surface and cladding when installing cladding in Canada in accordance with the NBC, Section 9.27.2.4.(2) or local building code requirements.]*

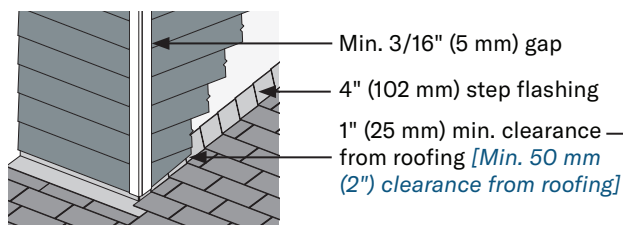

Roofing Option - Siding
Figure 2a

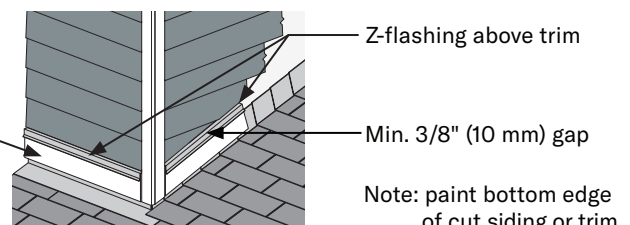

Roofing Option - Trim
Figure 2b

FLASHING (CONT'D.)

KICK-OUT FLASHING

- Install kick-out flashing at roof eave-to-wall intersections to direct water into gutter.
- **DO NOT extend siding or trim into kick-out flashing or gutter.**
- Maintain 1 inch (25 mm) clearance between the end of the gutter and the adjoining wall to allow for proper maintenance of the siding.

Kick-out flashing
Do not run siding
or trim inside of
kick-out flashing

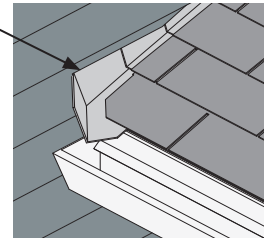

Figure 3a

MOISTURE

- Moisture and vapor control are critical elements of proper housing design.
 - Check your local building code for requirements for handling moisture and water vapor in your area.
 - Do not apply engineered wood siding to a structure having excessive moisture conditions such as drying concrete, plaster or wet blown cellulose insulation.
 - If such conditions exist, building should be well ventilated to allow to dry prior to siding application.
 - When using wet blown cellulose insulation it must not be in direct contact with the siding, and it must be allowed to dry a min. of 24 hours or longer if specified by the insulation manufacturer.
- Siding must not be installed on green or crooked studs.
- Do not apply siding over rain-soaked or buckled sheathing.

WATER-RESISTIVE BARRIER (WRB)

- A properly installed WRB is required behind siding, unless exempt by building code.
- LP assumes no liability for water penetration or any other issues associated with the WRB.

FASTENING INSTRUCTIONS

STUD SPACING OPTIONS

- Siding may be attached **direct to studs** spaced max. 16 inches (406 mm) o.c.
- Siding may be attached **directly to wood structural panel sheathing**, min. 7/16 Performance Category, with studs spaced a max. 24 inches (610 mm) o.c.

INSTALLATION

- Begin by nailing a starter strip 3/8 inch (10 mm) thick x 1-1/2 inches (38 mm) wide, flush with bottom edge of sill plate.
 - Starter strip serves two purposes
 - Provides separation of siding from CMU or poured concrete foundation. (Figures 6b, 6c, 6d)
 - Provides proper angle to first course of siding.
 - Exception: starter strip may be omitted if separation from concrete is maintained. Separation can also be achieved by ensuring WRB is placed behind siding.
- Install siding blind-nailed, place nail a min. of 3/4 inch (19 mm) from the top edge.
 - Refer to Figure 4a for fastener placement at butt joints.
 - Overlap successive courses of lap a min. 1 inch (25 mm).
 - Shim siding at studs as needed to avoid drawing siding against uneven walls.
 - Nails will be exposed on siding located immediately below window sills, fascia boards, or horizontal trim and shall be spaced a max. 8 inch (203 mm) o.c. (Figure 10d)
- Use a min. 0.092 inch shank diameter, hot-dip galvanized nail (ASTM A153) or equivalent; capable of preventing rust, stain and deterioration under normal outdoor environmental conditions for a period of no less than 50 years. Penetrate studs or combination of WSP sheathing and studs a min. of 1-1/2 inches (38 mm).
 - A larger 0.113 inch shank diameter nail may be required depending on the wind pressure, wind speed and wind exposure category limitations in PR-N124 or ESR-1301. Penetrate studs or combination of WSP sheathing and studs a min. of 2 inches (51 mm).
- Install bottom side of shiplap first. (See Figures 4a, 8a)
 - Avoid sliding or forcing bottom shiplap into place, if top shiplap has been installed first.
- Nail from the center of the siding toward the ends, or from one end to the other end. NEVER nail from the ends of the siding toward the middle.

FASTENING INSTRUCTIONS (CONT'D.)

- Shiplap must be removed to full panel thickness and caulked at window, door and vertical trim intersection. (Figure 4b)
 - Backer rod recommended at 3/16 inch (5 mm) gap.
- Painting all exposed nail heads is recommended.
- Do not overdrive nails.
 - Nail head should seat snug to face of siding, but not countersunk which is considered overdriven.
 - **Blind nails:** only correction required would be re-nailing when countersunk more than 1/8 inch.
 - **Face nails:** will occur immediately below window sills, soffit, freeze boards and horizontal trim. Corrections detailed below. (Figure 4a)

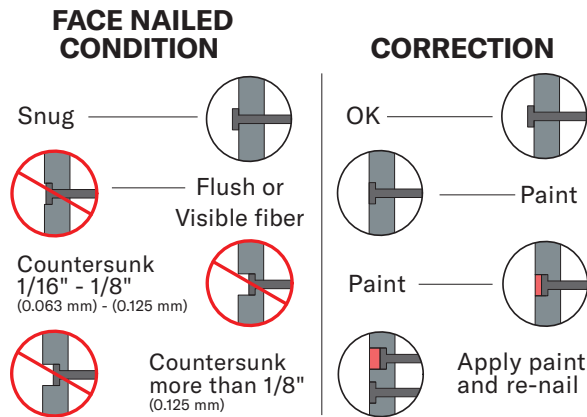

Figure 4a

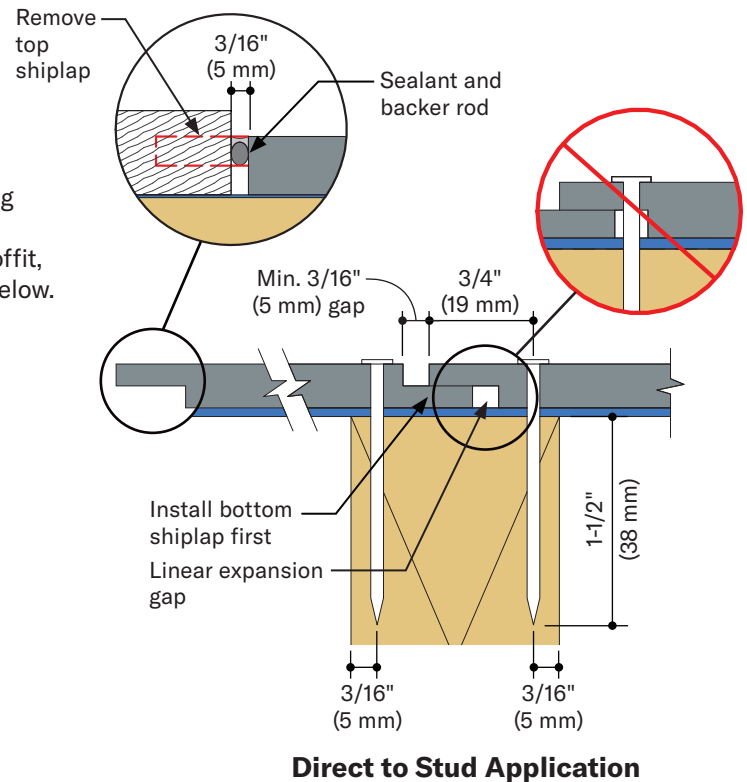

Figure 4b

BUTT JOINTS

- Butt joints must occur over studs. (Figure 4b)
 - Exception: sheathing only applications. (Figure 8a)
- Stagger butt joints a min. of 16 inches (406 mm).
 - Stacking or stair-stepping butt joints is not recommended as it may cause an undesirable appearance.
- LP® SmartSide® ExpertFinish® Prefinished Lap Joint Siding is designed with a shiplap butt joint which eliminates the need for sealant/caulk. **Do not caulk butt joint.**
- **Provide a min. 3/16 inch (5 mm) gap at butt joint.** (Figure 4c)
 - Use spacing tool like SIMPLESIDER® (Figure 4d) or rafter square (Figure 4e) to achieve proper gapping.
 - Rafter square thickness varies between manufacturers.
 - Confirm spacing tool is a min. 3/16 inch (5 mm) in thickness before using.
 - Gapping will allow for linear expansion of siding.

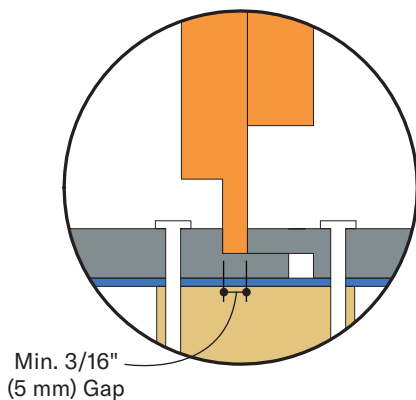

Figure 4c

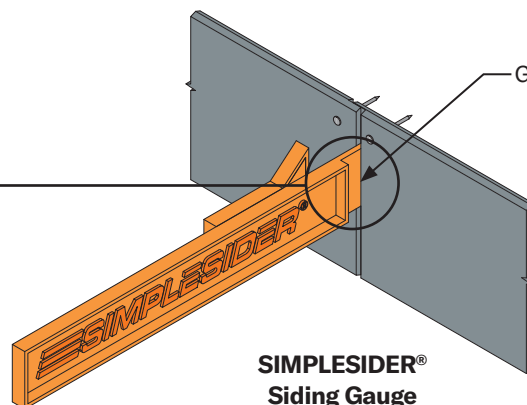
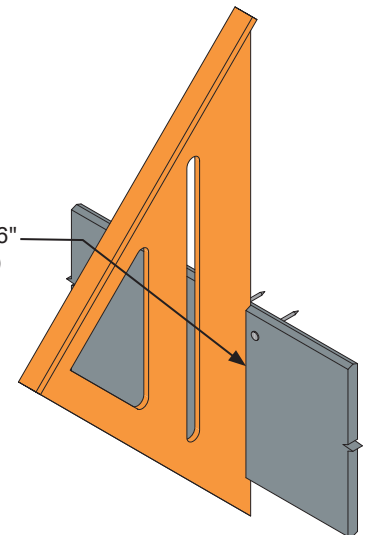

Figure 4d



Rafter Square
Figure 4e

FASTENING OPTIONS OVER FOAM PLASTIC SHEATHING (RIGID FOAM INSULATION)

- Lap siding may be installed directly over foam sheathing.

FOAM PLASTIC SHEATHING ≤ 1 INCH (25 MM)

- Increase nail length to ensure a min. 1-1/2 inch (38 mm) penetration into studs, or combination of studs and WSP sheathing (Figure 5a), or WSP sheathing only attachment. (Figure 5b)

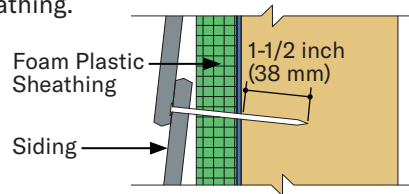

Figure 5a

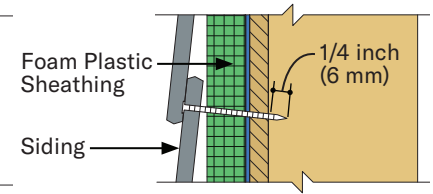

Figure 5b

FOAM PLASTIC SHEATHING > 1 INCH (25 MM)

- Siding attachment: Refer to IRC Chapter 7, Wall Covering for prescriptive siding attachments over foam sheathing up to 4 inches (102 mm) thick, direct to wood or steel studs for support of siding weight only. **Does NOT include wind loads.**
 - Refer to Table 703.15.1 for min. fastening requirements over foam sheathing to wood studs.
 - Refer to Table 703.16.1 for min. fastening requirements over foam sheathing to steel studs.
- Fastener placement:
 - Nail spacing depends on siding attachment method; Direct to Stud or wood structural panel (WSP) sheathing attachment, and
 - Wind load limitations in [PR-N124](#) or [ESR-1301](#).
- LP assumes no liability for loss or damage associated with fastening requirements of the applicable code.

FURRING OVER FOAM PLASTIC SHEATHING

- Use a min. 3/4 inch (19 mm) thick x 3-1/2 inch (89 mm) wide Southern Pine furring strip with a specific gravity ≥ 0.55.
 - 38 Series lap siding may be attached to furring spaced a max. 16 inches (400 mm) o.c.
 - Depending on wind load limitations in [PR-N124](#) or [ESR-1301](#).

- Furring attachment direct to wood or steel studs:
 - Refer to IRC Chapter 7 on Wall Covering for prescriptive furring attachment over foam sheathing up to 4 inches (102 mm) thick.
 - Refer to Table 703.15.2 furring min. fastening requirements over foam sheathing to wood studs.
 - Refer to Table 703.16.2 furring min. fastening requirements over foam sheathing into steel studs.

- Siding attachment to furring: (Figures 5c)
 - Use a min. 0.120 inch diameter **ring shank**, hot-dip galvanized nail (ASTM A153) or equivalent.
 - Nail length must be long enough to penetrate min. 1/2 inch (13 mm) into furring.
 - Place nail 3/4 inch (19 mm) from top edge of siding.
 - Increase min. overlap to 1-1/8 inch (29 mm).
 - Blind nail two fasteners per furring strip (four nails at butt joints). (Figure 5d)

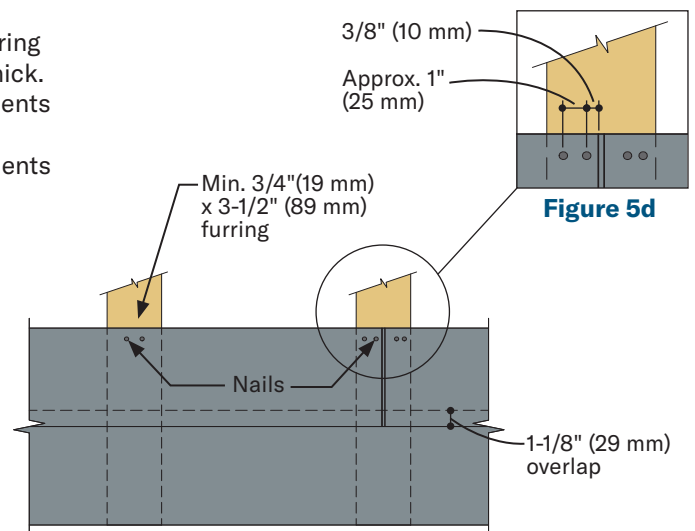

Figure 5c

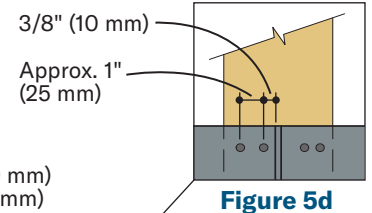

Figure 5d

ADDITIONAL FASTENING OPTIONS ≤ 1 INCH (25 MM)

EXTERIOR GYPSUM SHEATHING

- Siding may be installed over exterior gypsum sheathing, according to the following:
 - Adequate bracing of the wall is provided in accordance with the local building code.
 - Nail length must be increased to ensure a min. 1-1/2 inch (38 mm) penetration into wood studs, or combination of WSP sheathing and wood studs.

EXISTING WOOD SIDING OR WOOD COMPOSITE SIDING

- Siding may be installed over existing wood or wood composite siding, if the existing siding does not affect the ability to correctly install siding.
 - A properly installed WRB is required between the existing siding and the new siding.
 - A uniform surface behind siding is required to avoid contouring of siding.
 - Do not install over existing siding that is not flat or uniform.
 - Min. nail penetration and max. stud spacing must not be compromised.
 - Ensure wall assembly meets structural requirements specified in building code and by local code authority.
 - Repair any areas of the existing siding that are not structurally sound, not installed correctly, or exhibit signs of decay.

ADDITIONAL FASTENING OPTIONS (CONT'D.)

CONCRETE MASONRY UNIT (CMU) OR POURED CONCRETE

- Non-Compressible Drainable Housewrap (NCDH) is required behind siding installed over CMU or poured concrete walls.
 - Refer to [Technical Bulletin #031](#) for definition of NCDH.
 - Attach NCDH to wall per manufacturer's instructions or use a min. 3/8 inch (10 mm) stub nail.
 - Properly tape and/or seal wall penetrations in accordance with the NCDH manufacturer's instructions.
- Siding attachment: Use fasteners suitable for CMU or poured concrete walls as specified by the fastener manufacturer.
 - Use a fastener with a min. allowable withdrawal capacity and fastener head pull-through capacity of 62 lbf/nail (276 Nf/nail) or greater, based on load duration factor of 1.6.
 - Min. shank diameter = 0.140 inch (3.6 mm).
 - Min. length = 1.25 inches (32 mm).
- Commonly used concrete fasteners include, but not limited to Aerosmith® Power-Pin™ 5323HPG PT2000 plating, head diameter 0.300 inch (7.6 mm) x shank diameter 0.145 inch (3.7 mm) x length 1.25 inches (32 mm), smooth shank.
- Fastener placement:
 - Install blind-nailed a max. 10 inches (254 mm) o.c. with fastener placed 3/8 inch (10 mm) from either end, a min. 3/4 inch (19 mm) from the top edge of the board.
 - Immediately below window sills, frieze boards and horizontal trim nails will be exposed every 10 inches (254 mm) o.c.
 - Overlap siding a min. 1 inch (25 mm).

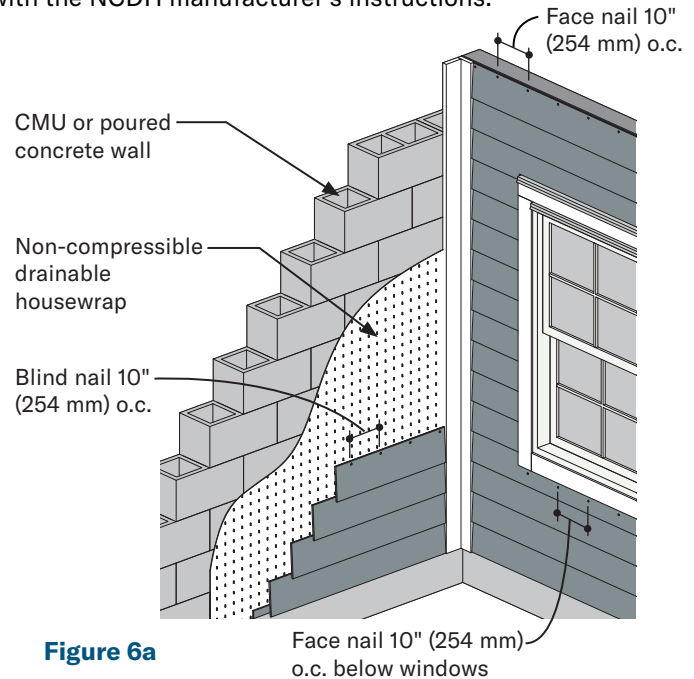

Figure 6a

FIRE-RATING

CAL FIRE WUI

- California Building Code, Chapter 7A [SFM] Materials and Construction Methods for Exterior Wildfire Exposure compliance can be achieved using LP® SmartSide® lap siding installed as described in:
 - CAL FIRE BML# 8140-2027:0001 over 1/2" (13 mm) standard gypsum wallboard applied behind lap on exterior side of framing; or
 - CAL FIRE BML# 8140-2027:0005 atop LP® FlameBlock® sheathing.

FIRE-RATED WALL ASSEMBLY

- LP SmartSide lap siding may be installed over the exterior portion of a 1-hour fire-resistive exterior wall assembly, including assemblies using gypsum wallboard listed in the Gypsum Association Fire Resistance Design Manual.
- For information on fire-rated wall assemblies: <https://lpcorp.com/products/panels-sheathing/fire-rated-osb-sheathing/assemblies>

OVERLAP, CLEARANCE & NAIL PLACEMENT

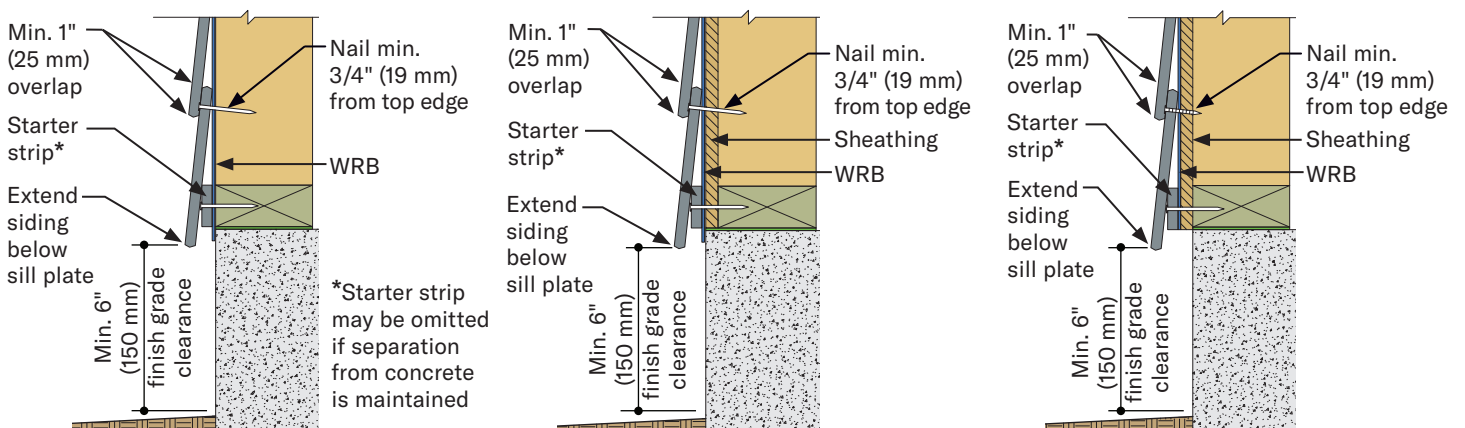

Siding - Direct to Stud Attachment

Figure 6b

Siding - Direct to Stud w/WSP Attachment

Figure 6c

Siding - WSP Sheathing Attachment

Figure 6d

SIDING OR TRIM ADJACENT TO STUCCO/MASONRY

- Where siding is installed adjacent to stucco, brick, cultured stone, mortar, etc.
 - Leave a 3/8 inch (10 mm) gap and caulk.
 - Backer rod may be required by caulking manufacturer.

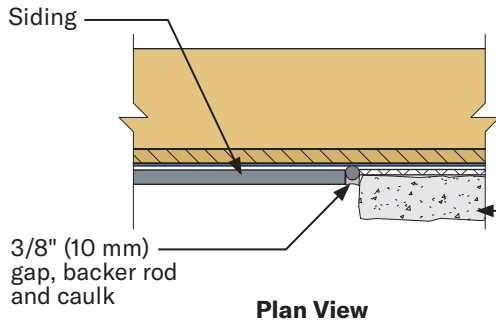

Plan View

Figure 7a

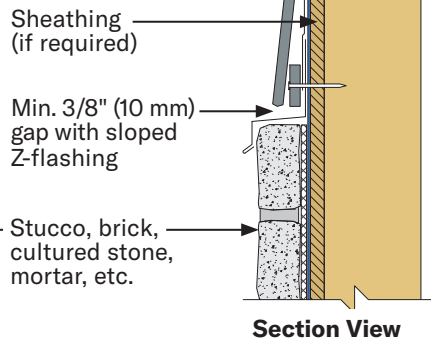

Section View

Figure 7b

Do not install LP® SmartSide® trim as brick sill

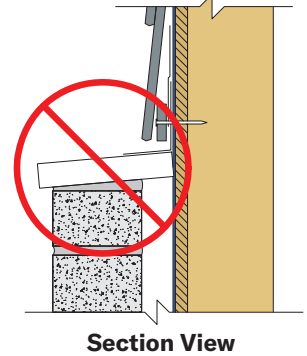

Section View

Figure 7c

FINISHING INSTRUCTIONS

- When sealant is required, use a high-quality, non-hardening, paintable sealant meeting ASTM C920, minimum Class 25.
 - Follow sealant manufacturer's instructions for application.
- Paint all exposed surfaces, including all drip edges or where water will hang. For best results, use a high-quality 100% acrylic exterior paint specially formulated for use on wood and engineered wood substrates; oil paint is acceptable.
 - DO NOT USE stain or vinyl-based paint.
 - Apply paint as soon as possible or within 180 days.
 - Follow paint manufacturer's instructions for application.
 - Follow LP's Care & Maintenance Instructions.

BRUSHED SMOOTH Lap Siding:

- Either flat, satin or semi-gloss coatings can be applied to brushed smooth finish lap siding.
 - Each offers different appearance & maintenance benefits.

CEDAR TEXTURE Lap Siding:

- For best results use semi-gloss finish.
- Touch up any damage to finish that may occur during application
- Apply touch up paint to cover scratches less than 1 inch (25 mm) in length and less than 1/16 inch (2 mm) wide, exposed nail heads and small nicks.
- Do not apply touch up paint to spots greater than 3/4 inch (19 mm) in diameter.
- Touch up paint should be used sparingly.
 - Apply touch up paint only when air, siding and paint temperature are above 50°F.
 - Store touch up paint between 40°F and 100°F.
 - Shake touch up paint for 90 seconds before every use.
 - Do not use touch up paint if you suspect it has frozen.
 - Do not apply touch up paint to wet siding.
 - Avoid touch up painting when condensation likely to form.
 - Avoid touch up painting when precipitation is possible.
- The touch up paint is air dried, while the factory applied coating is cured using ovens. For this reason, the touch up paint will have some minor differences initially and after time. Minimizing the use of touch up paint is the best approach to help ensure these minor differences are less noticeable.
- Use the appropriate applicator provided in the LP® SmartSide® ExpertFinish® Touch-Up Kit.
 - Nail Head Paint Applicator (Figure 7d)
 - Cut End Paint Applicator (Figure 7e)
- For additional touch-up paint, please call 888-820-0325.



Figure 7d

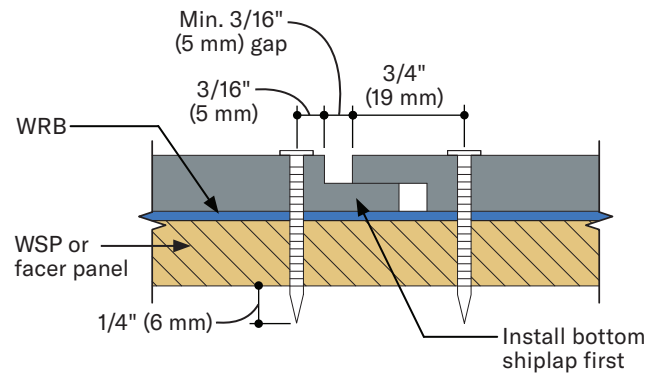

Figure 7e

ALTERNATE FASTENING OPTIONS

WOOD STRUCTURAL PANEL (WSP) SHEATHING OR SIP ASSEMBLIES

- WSP wall sheathing must be a min. 7/16 Category with APA Trademark that contains the consensus Standard DOC PS 2.
- Siding may be nailed to SIP or WSP sheathing. (Figure 8a)
 - Min. 0.092 inch diameter **ring shank**, hot-dip galvanized nail (ASTM A153) or equivalent.
 - Nail length must be long enough to fully penetrate sheathing by at least 1/4 inch (6 mm). (Figure 8b, 8c)
 - Ensure that the ring shanks of the nail fully engage the wood structural panel sheathing.
 - Space fasteners depending on the wind pressure, wind speed and wind exposure category limitations in [PR-N124](#), Table 4a or 4b; or [ESR-1301](#), Table 4a or 4b.



Sheathing Only Application
Figure 8a

STEEL STUD FRAMING ASSEMBLIES

- Siding must be fastened with:
 - Min. #8 stainless steel or equivalent, self-drilling tapered head screw.
 - Min. of 5 threads beyond the combined thickness of the siding and steel stud framing. (Figures 8d, 8e)
- Min. steel stud thickness of 0.032 inch (8 mm) or 20 gauge.
- Min. withdrawal value of steel stud must be 50 lbs. (23 kg).
 - Refer to steel stud manufacturer's evaluation report.

INSULATED CONCRETE FORMS (ICF) ASSEMBLIES

- Web flange must be wide enough to accommodate fastener spacing requirement at butt joint. (Figures 8a)
- Siding must be fastened with:
 - Min. #8 stainless steel or equivalent, self-drilling tapered head screw.
 - Min. penetration of 3/8 inch (10 mm) beyond thickness of the nailing flange.
- Larger screws may be required by ICF Manufacturer based on the following min. withdrawal requirements.
 - Min. withdrawal value of ICF nailing flange must be 50 lbs. (23 kg) with max. 12 inches (305 mm) o.c. spacing.

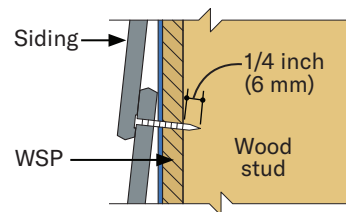

Siding nailed to WSP Sheathing Wood Stud
Figure 8b

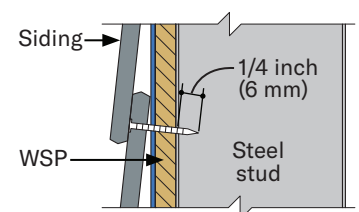

Siding nailed to WSP Sheathing Steel Stud
Figure 8c

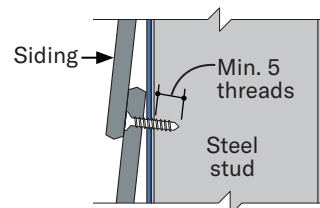

Siding fastened to Steel Stud
Figure 8d

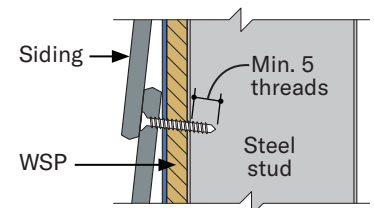

Siding fastened to Steel Stud
Figure 8e

LAP SIDING INSTALLED VERTICALLY

- Siding must be installed in a sheathing only attachment method over min. 7/16 Category WSP sheathing with an APA Trademark that contains the consensus Standard DOC PS 2.
 - Exception: can be installed over LP® FlameBlock® Fire-Rated OSB Sheathing.
- The edges of lap siding installed vertically must be spaced a min. of 3/16 inch (5 mm) from each other. (Figures 10a, 10b)
- Due to expected plate shrinkage, each vertical application of battens or lap siding is not to span beyond one floor to ceiling distance, or one floor to top of gable distance. (Figures 9b, 9c)
 - Exception: residing existing structures.
- Siding may be applied over an entangled mat WRB. Ensure mat is rigid enough to receive siding to avoid a wavy or inconsistent appearance.
 - Exception: lap siding installed horizontally is not approved for use over entangled mat products.
- Remove shiplap to full panel thickness at top and bottom of wall. (See Figures 8f, 8g)

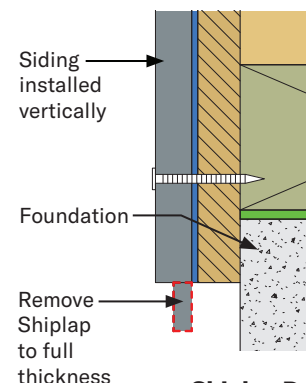

Shiplap Detail at Bottom of Wall
Figure 8f

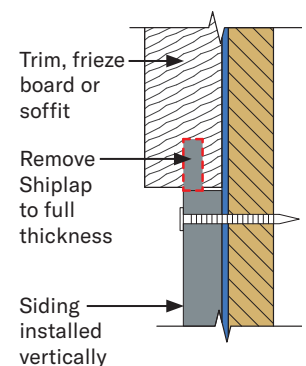

Shiplap Detail at Top of Wall
Figure 8g

ALTERNATE FASTENING OPTIONS (CONT'D.)

- DO NOT bridge floors with lap installed vertically or battens. (Figures 9c)
 - Create a horizontal joint between floors.
 - Joint must be flashed with sloped Z-flashing, which would require removal of shiplap edge. (Figures 9a)
- Siding nail requirements:
 - Use a min. 0.092 inch diameter **ring shank**, hot-dip galvanized nail (ASTM A153) or equivalent.
 - Nail shall be long enough to fully penetrate WSP sheathing by at least 1/4 inch (6 mm). Ensure that the ring shanks of the nail fully engage the WSP sheathing.
 - **Caution:** nail length should be chosen to reduce possible damage to wiring or utilities in wall.
 - Place nails 3/8 inch (10 mm) from ends and edges.
 - Nail spacing for lap siding installed vertically or lap over lap:
 - Place with two nails at both ends, with additional nails spaced a max. of 6 inches (152 mm) o.c. along alternating edges (Figure 9d)
- Batten nail requirements:
 - Use a min. 0.092 inch diameter **ring shank**, hot-dip galvanized nail (ASTM A153) or equivalent.
 - Ring Shank nails provide superior resistance to nail pull-through. In Hurricane-Prone Regions or locations where negative wind loads are a concern, ring shank nails should be used.
 - Finish nails may be used in other locations with the following cautions: Do not overdrive or counter sink the fastener, nail snug with the surface of batten.
 - Place nails 3/8 inch (10 mm) from ends and edges.
 - Nail Spacing for Battens: Place two nails at both ends, with additional nails spaced a max. 12 inches (309 mm) o.c. along alternating edges the length of batten. (Figure 9e)
 - Exception: for battens 1-1/2 inches (38 mm) wide or less, one nail is required at each end with additional nails spaced a max. 24 inches (305 mm) o.c. along alternating edges. (Figure 9f)
 - Batten may be a min. 1/2 inch (13 mm) x 1-1/2 inch (38 mm) wide.
 - Caution: when selecting batten less than 2-1/2 inches (64 mm) wide, it may be difficult for batten to conceal nail heads.
 - Visible nail heads that are not covered by battens are an aesthetic issue and not covered under Limited Warranty.
 - Detachment of batten is not covered by the LP SmartSide limited warranty whether ring shank or finish nails are used.

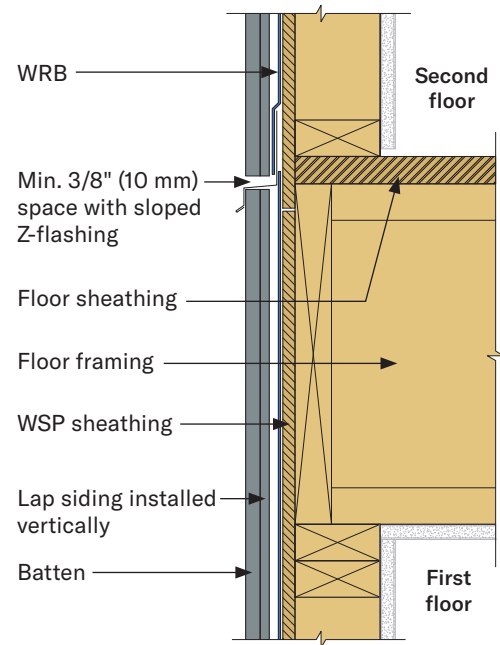

Figure 9c

Floor-to-Floor

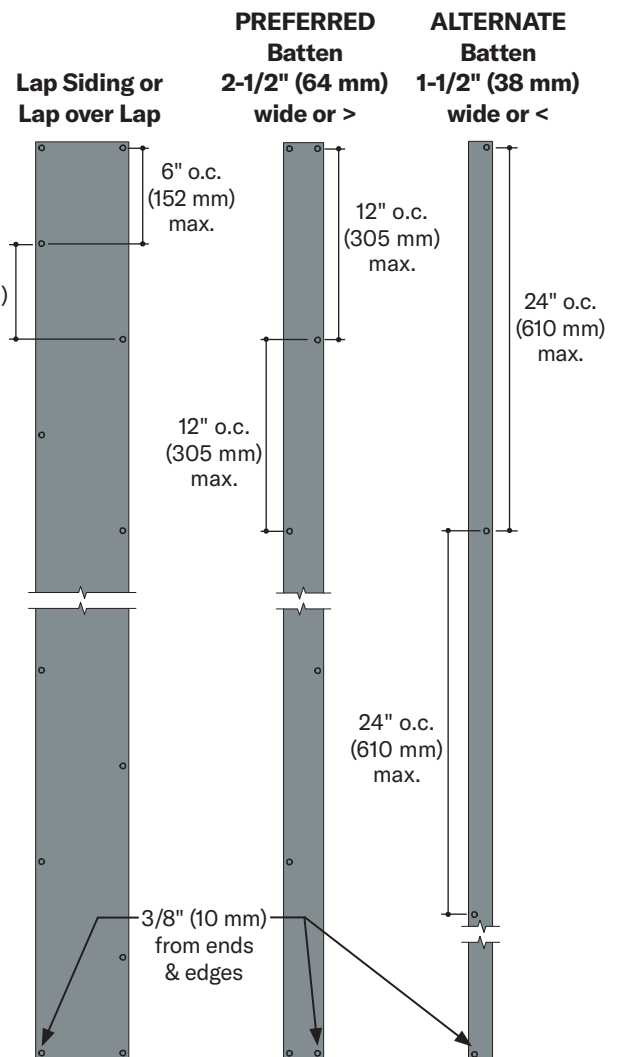

Figure 9d

Figure 9e

Figure 9f

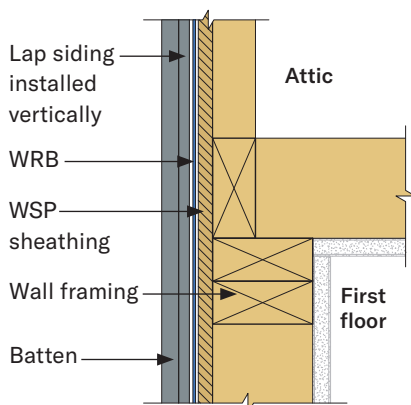
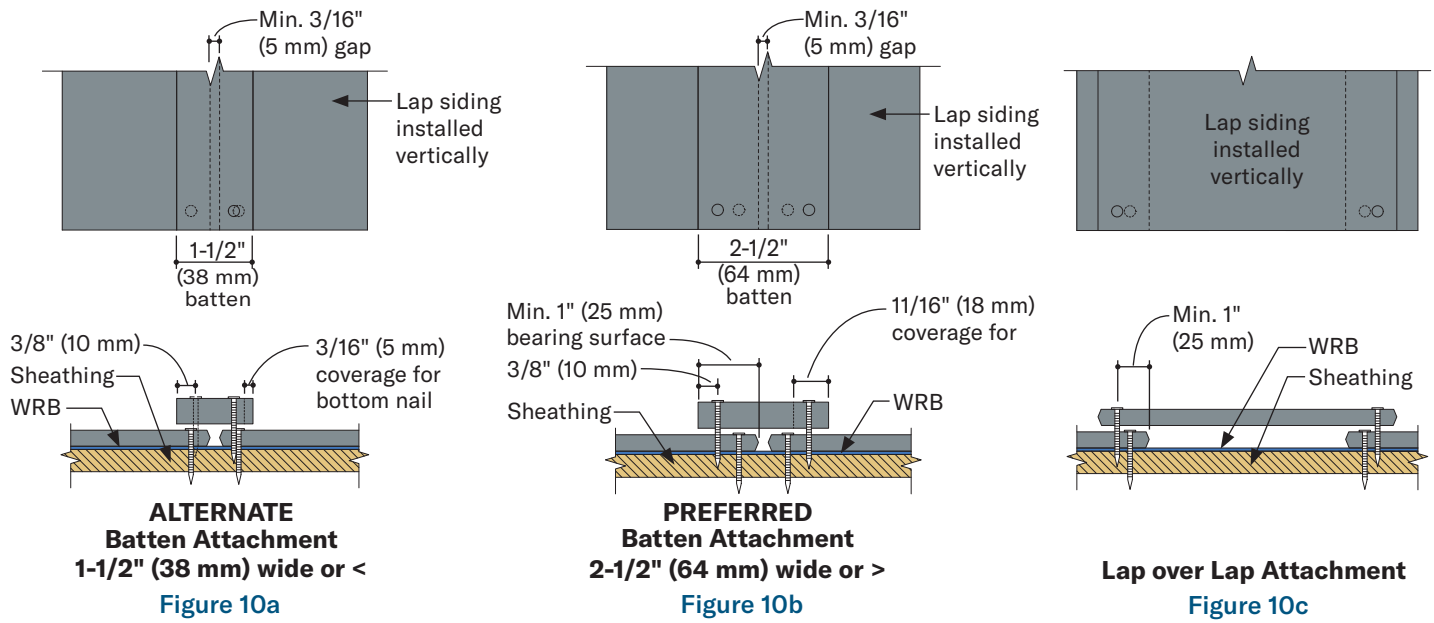

Figure 9b

Attic over Floor

ALTERNATE FASTENING OPTIONS (CONT'D.)



GENERAL INFORMATION

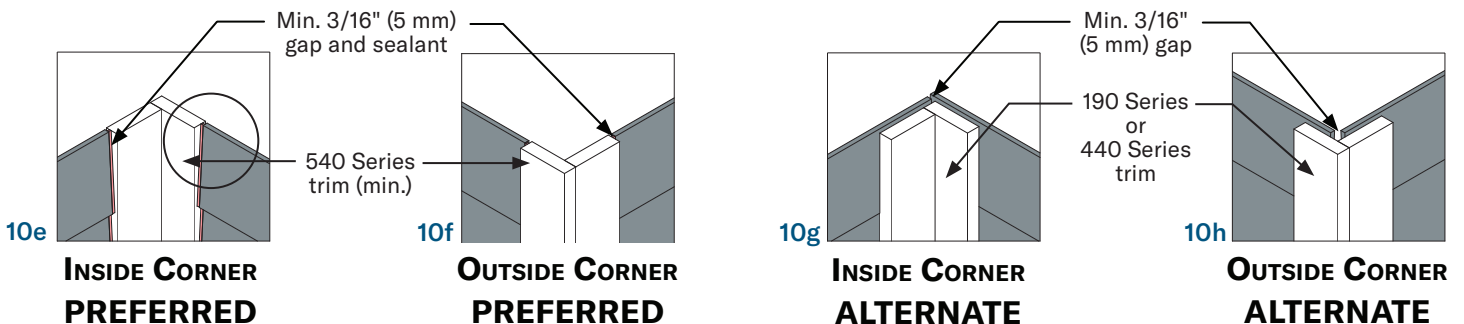
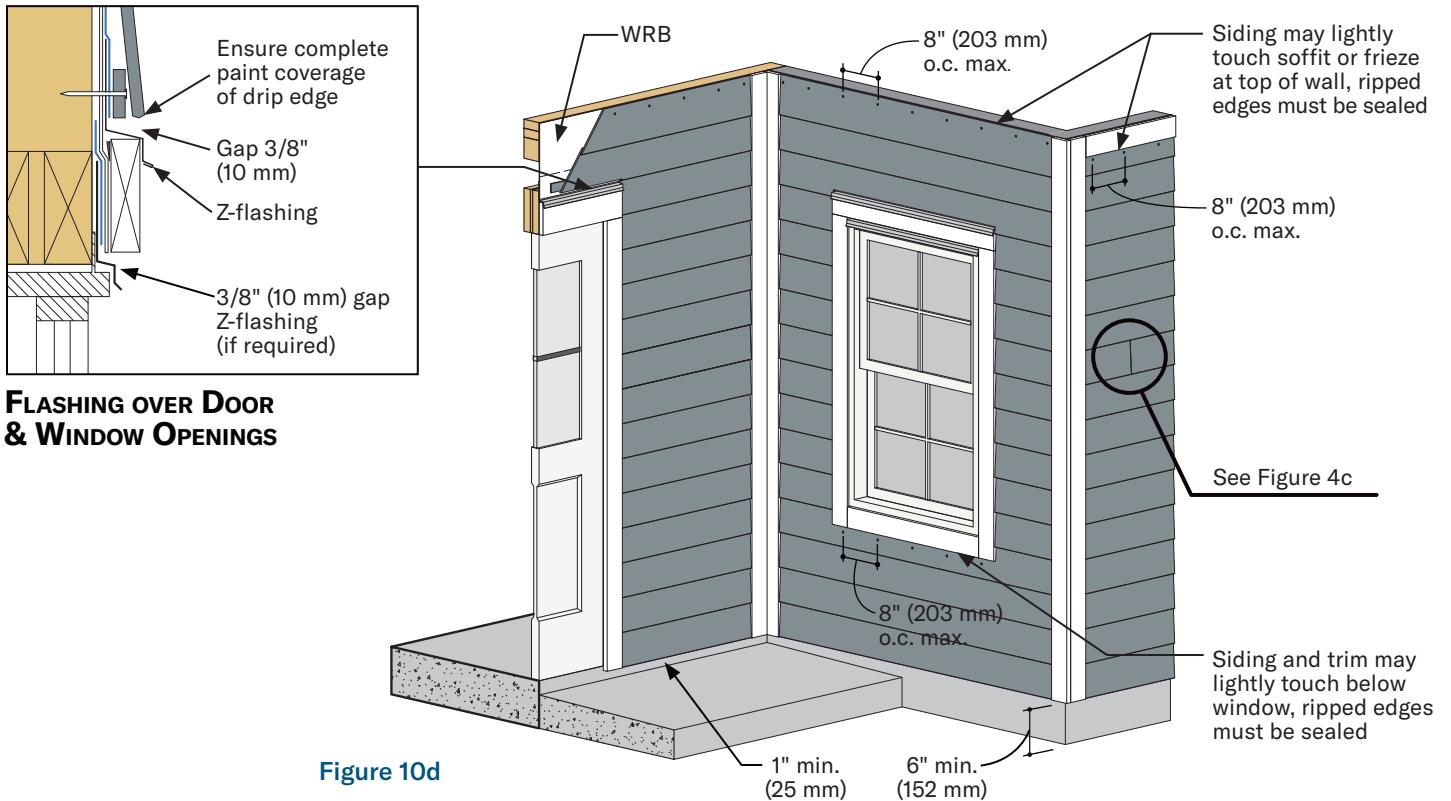

WOOD FRAMED WALL ASSEMBLIES - EXAMPLES

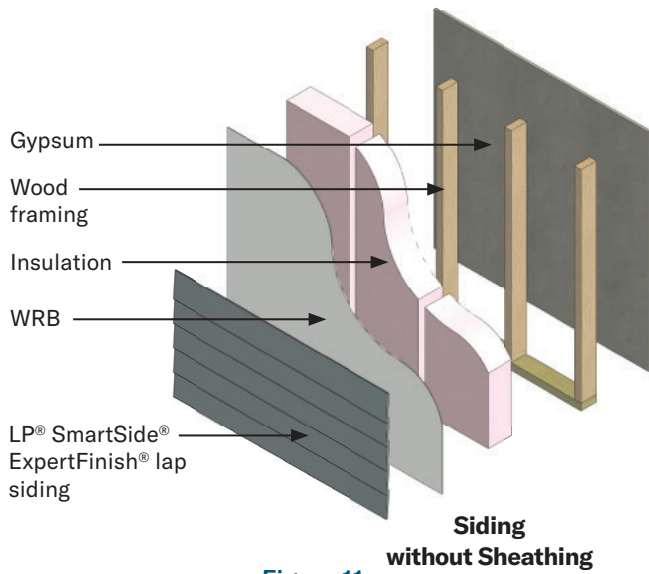

Figure 11a

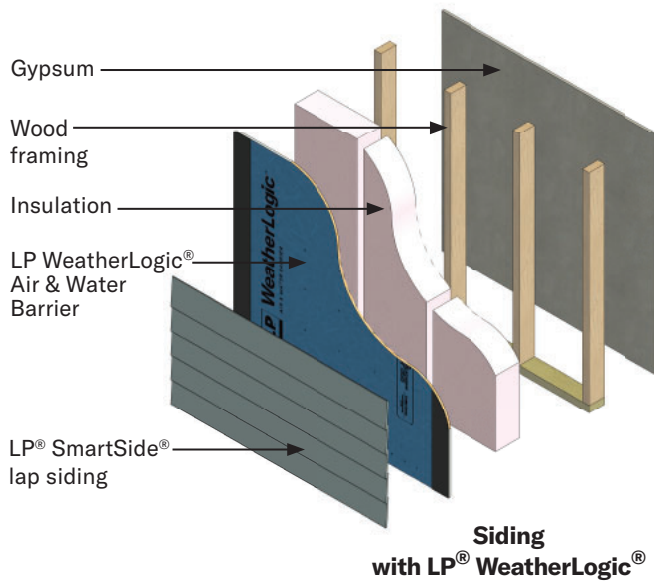

Figure 11c

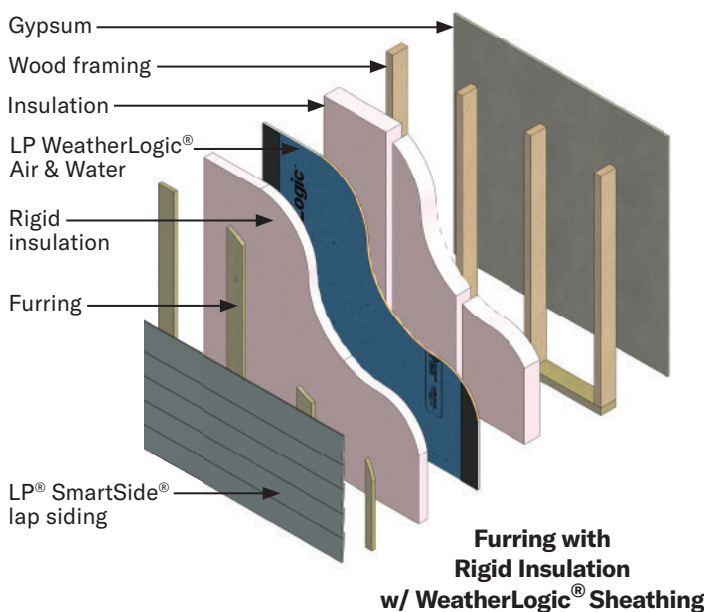

Figure 11e

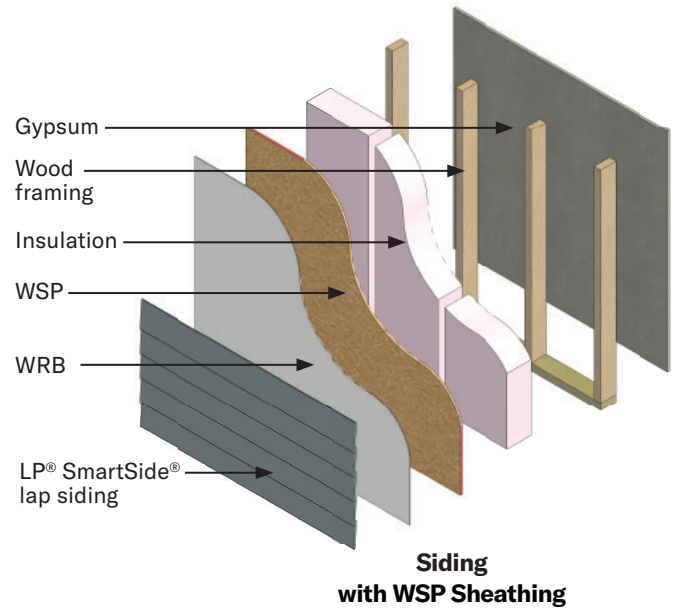

Figure 11b

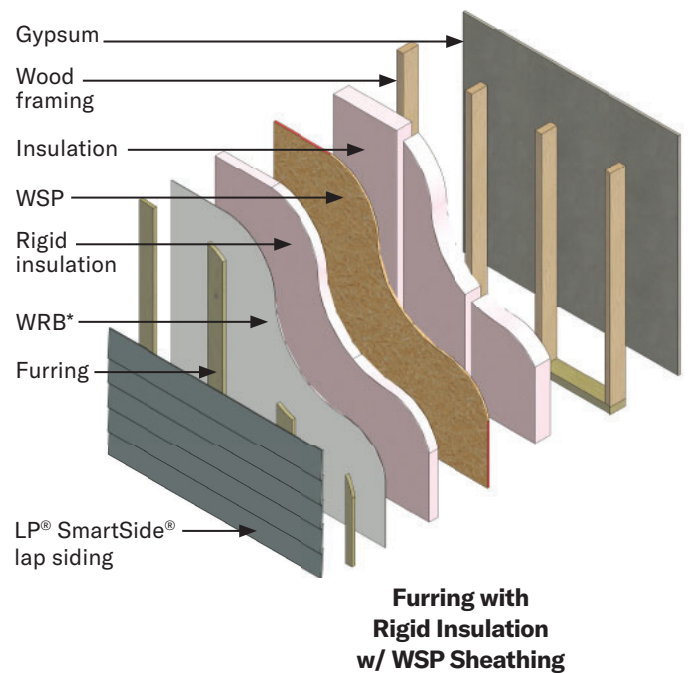

Figure 11d

* WRB location in wall assembly may vary depending on climate zone or other factors.

©2024 Louisiana-Pacific Corporation. All rights reserved. LP and SmartSide are registered trademarks of Louisiana-Pacific Corporation. Printed in U.S.A.

LPEF0028 04/26/2024

LP® SmartSide® ExpertFinish® Lap Siding

Application Tips

IMPORTANT Always refer to the complete application instructions for the product you are installing. The application tips provided below are not intended to replace such instructions. Application instructions can be found at LPCorp.com. Failure to follow the full application instructions could cause personal injury or property damage, affect system performance, void any applicable warranty and/or violate applicable building codes.

Exercise safe practices at all times while handling and using this product. Refer to the relevant Safety Data Sheet (SDS) for important information on the safe handling and use of this product. These can be found at LPCorp.com.

- Lap siding may be attached Direct to Studs or Direct to Wood Structural Panel (WSP) Sheathing:
 - **Direct to Stud** - nails must penetrate structural framing, or combination of WSPs and structural framing min. 1-1/2" (38 mm), some installations may require 2" (51 mm) penetration see [PR-N124](#) or [ESR-1301](#)
 - **Direct to WSP Sheathing** - nails must be long enough to penetrate beyond WSP by 1/4" (6 mm)
- Stud spacing – see application instructions for spacing from 16" (406 mm) o.c. to 24" (610 mm) o.c.
- See application instructions for alternative nailing options for: SIP, steel studs, ICF's and lap siding installed vertically.
- Nail size:
 - **Direct to Stud** – a min. 0.092" shank diameter hot-dip galvanized (ASTM A153) nail may be used, some installations may require a larger 0.113" shank diameter depending on wind pressure, wind speed and wind exposure limitations in PR-N124 or ESR-1301
 - **Direct to WSP Sheathing** - a min. 0.092" shank diameter hot-dip galvanized (ASTM A153) **ring shank** nail
- Nail placement – 3/8" (10 mm) from siding end and edges and a min. of 3/4" (19 mm) down from top edge of siding
- Nail spacing:
 - **Direct to Stud** – one nail every 16" (406 mm) o.c.
 - **Direct to WSP Sheathing** – nailing pattern varies from 8" (203 mm) o.c. to 12" (305 mm) o.c. depending on the wind pressure, wind speed and wind exposure limitations in PR-N124 or ESR-1301
- Overlap – min. of 1" (25 mm), siding shall not project beyond the face of trim
- Do not overdrive nails – nail head should seat snug to the face of siding, if overdriven - see Application Instructions
- Caulk – use a high-quality, non-hardening, paintable exterior sealant meeting ASTM C920, min. Class 25
- Seal all exposed substrate – sealing can be accomplished by applying a paint or caulk
- Provide a min. 3/16 inch (5 mm) gap at butt joint.
 - Use spacing tool like SIMPLESIDER® or rafter square to achieve proper gapping.
- Siding clearance at finish grade (ground cover) – min. 6" (152 mm) *[Min. 200 mm (8 inch) clearance must be maintained between cladding and finish ground when installing cladding in Canada.]*
- Siding clearance adjacent to surfaces such as porches, patios, or porch columns, etc. – min. 1" (25 mm):
 - May be reduced to 3/8" (10 mm) – see Application Instructions
- Siding must not be in direct contact with CMU, poured concrete, brick, cultured stone, stucco, mortar, etc.
- Flashing is required above all windows, doors and horizontal trim per manufacturer's instructions:
 - Flashing shall be metal or another durable material that will last for not less than 50 years
 - Provide 3/8" (10 mm) gap above any drip cap flashing, do not caulk gap
- The piece of lap siding below a windowsill or frieze board will require face-nailing - see Application Instructions
- Siding over foam plastic sheathing adds complexity to siding installation – see Application Instructions
- For Limitations of Use – see Application Instructions, Technical Notes, Technical Bulletins and NSA Bulletins
- See Application Instructions for Storage and Handling guidelines