



**SMARTSIDE®**  
TRIM & SIDING

## FOUNDATIONS 76 SERIES PRIMED LAP SIDING ARCHITECTURAL COLLECTION 76 SERIES PRIMED COLONIAL AND 120 SERIES PRIMED SELF-ALIGNING LAP SIDING

### GENERAL

- At the time of manufacture, siding meets or exceeds the performance standards set forth in Composite Panel Association ANSI 135.6 and has achieved code recognition under Legacy National Evaluation Report NER-626 and CCMC 12353. For copies of these reports, call LP Customer Support at 1-800-648-6893.
- Minimum 6 in. clearance must be maintained between siding and finish grade.
- Siding applied adjacent to porches, patios, walks, etc. must have a clearance of at least 1 in. above any surface.
- Minimum 1" clearance at intersection with roof line
- Apply siding in a manner that prevents moisture intrusion and water buildup.
- All exposed wood substrate must be sealed in a manner that prevents moisture intrusion and water buildup.
- In non-traditional ICF and SIP assemblies, the ICF or SIP manufacturer must prescribe the fastening specifications. Note: LP does not recommend LP SmartSide for use in these non-traditional assemblies. If used, LP will not warrant for Buckling and Shrinkage. However, balance of warranty does remain intact.
- When using wet blown cellulose insulation, the insulation must not be in direct contact with the siding and it must be allowed to dry a minimum of 24 hours or longer if specified by the insulation manufacturer.
- DO NOT USE STAPLES
- SIDING MUST NOT BE IN DIRECT CONTACT WITH MASONRY, CONCRETE, BRICK, STONE, STUCCO OR MORTAR.

### STORAGE

- Store off the ground well supported, on a flat surface, under a roof or separate waterproof covering
- Keep siding clean and dry. Inspect prior to application.

### STUD SPACING

- Siding may be applied over sheathed walls or, where building codes permit, directly to studs spaced no greater than 16 in. O.C. that have adequate corner bracing.
- In all installations over masonry or concrete walls, the wall shall be furred out and open at the top and bottom of the wall to allow for convective ventilation between framing spaced 16 in. O.C. The framing shall be of adequate thickness to accept 1-1/2 inches of nail penetration. A properly installed breath-

able water-resistant barrier is required between the siding and masonry or concrete walls.

- Foundations 76 Series and Architectural Collection 76 series primed colonial lap siding is not warranted against buckling in Alaska, Hawaii, Northern California or west of the Cascades in Washington, Oregon and California.
- In all installations over masonry walls, the wall must be furred out and open at top and bottom to allow for convective ventilation with framing spaced 16 in. O.C. and with adequate thickness to accept the full length of the recommended nail.

### MOISTURE

- Moisture control and water vapor control are critical elements of proper housing design. Check your local building codes for application procedures for handling moisture and water vapor in your area.
- As with all wood products, do not apply engineered wood siding to a structure having excessive moisture conditions such as drying concrete, plaster or wet blown cellulose insulation. If such conditions exist, the building should be well ventilated to allow it to dry prior to the application of the siding.
- When using wet blown cellulose insulation, the insulation must not be in direct contact with the siding and it must be allowed to dry a minimum of 24 hours or longer if specified by the insulation manufacturer.
- Siding must not be applied to green or crooked structural framing members. Do not apply siding over rain-soaked or buckled sheathing materials.
- Gutters are recommended for control of roof water run off.

### SECONDARY WATER-RESISTANT BARRIER

- A properly installed breathable water-resistive barrier is required behind the siding. Consult your local building code for details.
- LP will assume no responsibility for water penetration.

### GAPS & SEALANTS

- Seal all gaps with a high-quality, non-hardening, paintable sealant. Follow the sealant manufacturer's instructions for application.
- Use a high-quality exterior sealant meeting the ASTM C920, minimum Class 25 sealant.

## FLASHING, WINDOWS, DOORS & OPENINGS

- All openings must be properly sealed or flashed in a manner that prevents moisture intrusion or buildup. Several examples that accomplish this are shown on the following pages.

## KICK-OUT FLASHING

- Install kick-out flashing to direct the water into the gutter
- Install step flashing with minimum 4 in. upper leg
- Properly integrate flashing with the secondary water-resistive barrier. Use housewrap, flashing tape, z-flashing, or other items as needed to maintain the counterflashing principle.
- DO NOT extend the siding or trim into the kick-out flashing or gutter
- Maintain a clearance between the end of the gutter and the adjoining wall to allow for proper maintenance of the siding
- Prime and paint ALL exposed cut edges

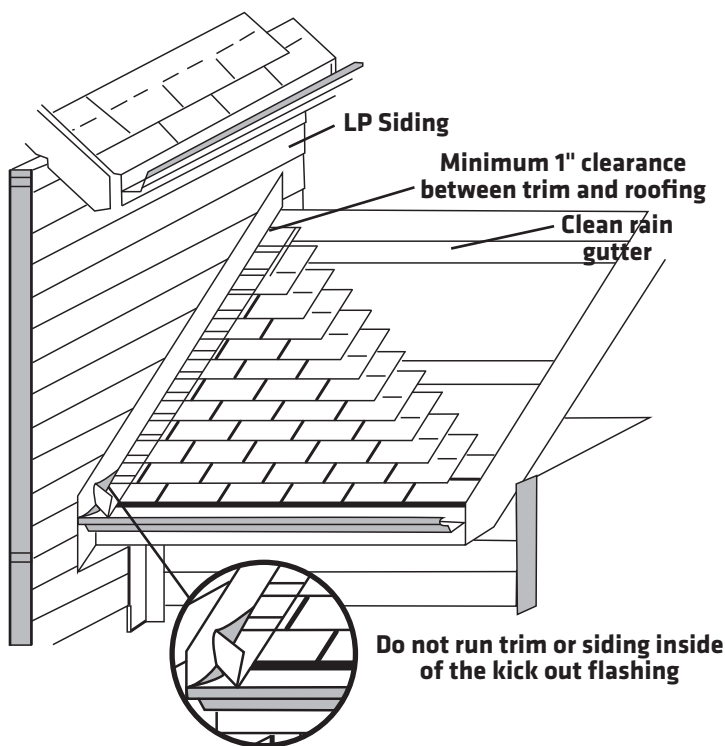

## TRIM

Trim should be thick enough so the siding does not extend beyond the face of the trim.

- Trim and fascia must be applied in a manner that will not allow moisture intrusion or water buildup.
- LP® SmartSide® siding are not designed and/or manufactured to be used as trim or fascia. LP SmartSide trim and fascia are available in a variety of dimensions.
- LP SmartSide lap siding is not designed and/or manufactured to be installed vertically.

## FINISHING INSTRUCTIONS

### DO

- **Prime and paint all exposed surfaces including all drip edges or where water will hang.**
- Apply finish coat as soon as possible or within 180 days of application.
- High-quality acrylic latex paint, specially formulated for use on wood and engineered wood substrates, is highly recommended. Semi-gloss or satin finish oil or alkyd paints are acceptable. For flat alkyd paint, please check with the coating manufacturer for their recommendations for use on composite wood siding.
- Follow the coating manufacturer's application and maintenance instructions.

### DO NOT USE

- Semi-transparent and transparent stains.
- Shake and shingle paints.
- Vinyl-based resin formulas such as vinyl acetate, PVA, vinyl acetate/acrylic copolymer paints.

**HANDLE PREFINISHED LP SMARTSIDE PRODUCTS WITH EXTREME CARE DURING STORAGE AND APPLICATION. TOUCH UP ANY DAMAGE TO THE FINISH THAT MAY OCCUR DURING APPLICATION PER PREFINISHERS SPECIFICATIONS.**

## NAILING INSTRUCTIONS

- Apply siding over a maximum stud spacing of 16 in. O.C. (See Stud Spacing)
- Begin by establishing a straight reference line to guide positioning the bottom edge of the first course of siding.











The suggested procedure is to measure equal distance downward from the eaves and/or windows and snap a chalk line.

This first step ensures that the siding appears parallel with the eaves, soffit, and windows, regardless of any actual setting of the house from true level.

**SIDING MUST BE APPLIED AT LEAST 6 in. ABOVE THE GROUND.**

- Snap parallel chalk lines on the walls as guides in positioning the top edge of each siding course. Space chalk lines so that bottom edge of the first course of siding is applied at least 6 in. above the ground, and that each subsequent siding course is overlapped a minimum of 1 in. (minimum 1-3/8 in. for Beaded Lap Siding).
- Nail a starter strip (wood lath or siding approximately 3/8 in. x 1-1/2 in.) 1/4 in. above bottom chalk line and install first course of siding.
- Penetrate structural framing or wood structural panels and structural framing a minimum of 1-1/2 in.
- Use hot-dipped galvanized nails with a minimum 0.270 in. diameter head and 0.113 in. diameter shank.

- Shim siding at studs, as needed, to avoid drawing siding against uneven walls. **DO NOT OVERDRIVE NAILS.** Nail head should seat firmly to face of siding but not be overdriven to distort the siding surface.
- Vertical butt joints must fall on studs. Nails should be placed at all stud locations and positioned 3/8" from the vertical edges on each side of the butt joint. Stagger butt joints on subsequent courses.
- Leave a 3/16 in. gap. All joints must be caulked with sealant. Optional joint moulding may be used. If joint moulding option is selected, add the thickness of the web to the gap allowing a net 3/16 in. space for expansion.
- Nail at all framing members around openings (maximum spacing 16 in. O.C.). Shim, if necessary, to provide solid backing for siding fitted around windows, doors, and at rake cuts on gable ends.

CONDITION		CORRECTION
Snug		OK 
Flush		OK 
Visible fiber		Paint 
Countersunk 1/16-1/8 IN.		Apply sealant 
Countersunk more than 1/8 in.		Apply sealant and re-nail 

- Where siding butts against window and door trim and at wood inside and outside corners, leave a 3/16 in. gap and seal.
- Nail from the center of the siding toward the ends, or from one end to the other end. **NEVER** nail from the ends of the siding toward the middle.
- Corner posts can be metal, wood, or vinyl. Trim should be thick enough so the siding does not extend beyond the face of the trim.
- Use drip cap flashing above all openings to ensure a weather-tight installation.
- Climb cut the surface of the siding such that the rotation of the blade cuts downward on the primed or prefinished surface.
- Where siding butts window trim, door casings and masonry, etc. leave a 3/16 in. gap and seal.
- For information on fastening LP SmartSide products in high wind speed areas, refer to ICC-ES Report ESR-1301 or APA Product Report PR-N124.

#### Alternative Fastening Option for (fiber) Blind Nailing

- **Limited to 6" and 8" wide lap siding, 9" and wider lap siding MUST BE face nailed.**
- Wood structural panels must be a minimum 7/16 inch Category

with an APA Trademark that contains the consensus Standard DOC PS 2.

- Foundations Series lap siding must be fastened with:
  - Minimum 8d (0.113 in. shank diameter) hot-dipped galvanized nail with a 0.270 in. diameter head spaced a maximum of 16 in. O.C. with fastener penetrating 1-1/2 in. into a stud.
  - Joints must always occur over stud locations.
  - Siding joints shall be staggered over successive courses.
  - Overlap successive courses of siding a minimum of 1".
  - Siding shall be installed with top (blind) nail placed 3/8" from each end, and 3/4 in. down from the top edge of the board.
  - Siding shall be face nailed 8 in. O.C. below window sills, frieze boards, and horizontal trim boards, with the bottom (face) nail placed 3/8" from either end and 3/8" from up from the bottom edge of the board.
  - Any exposed face nails must be sealed in a manner that prevents moisture intrusion and water buildup.

#### Alternative Fastening Options over Corrosion Resistant Steel Stud Framing

- Minimum withdrawal value of the steel framing must be 50 lbs. Refer to the framing manufacturer's evaluation report.
- Foundations lap must be fastened with:
  - Steel stud spacing a maximum spacing of 16 in. O.C.
  - Minimum #8 hot dipped galvanized tapered head self-drilling screw with a 0.270 in. diameter head.
  - Minimum of 5 threads beyond the combined thickness of the siding and framing.
  - Minimum steel framing thickness 0.032 in. or 20 gauge.

#### Alternative Fastening Option for (fiber) over Wood Structural Panels and 24 in. O.C. Stud Spacing

- Limited to 6 in. and 8 in. wide lap siding.
- Wood structural panels must be a minimum 7/16 Category with an APA Trademark that contains the consensus Standard DOC PS 2.
- Architectural Collection & Foundations lap must be fastened with:
  - Minimum 8d (0.113 in. shank diameter) hot dipped galvanized ring shank nail with a 0.270 diameter head, spaced a maximum of 8 in. O.C. and every 3rd fastener penetrating 1-1/2 in. into a stud or...
  - Minimum 6d (0.091 in. shank diameter) hot dipped galvanized ring shank nail with a 0.200 in. diameter head,

spaced a maximum of 4 in. O.C. and every 6th fastener penetrating 1-1/2 in. into a stud.

## Insulated Sheathings

LP SmartSide Siding may be installed over low-compression rigid foam or exterior gypsum. The following precautions must be followed:

- Adequate bracing of the wall in accordance with the International Codes or other ruling building code is required.
- For rigid foam sheathing up to 1 in. (25.4 mm) thick, siding may be nailed directly to the foam sheathing unless a drainage plane is required by the local building code. Nail length must be increased to ensure a minimum 1-1/2 in. (38.1 mm) fastener penetration into the structural framing.
- For rigid foam sheathing greater than 1 in. (25.4 mm), a minimum 1-1/2 in. (38.1 mm) thick by 3-1/2 in. (88.9 mm) wide vertical strapping or furring strip must be installed over the sheathing to provide a solid, level nailing base for the siding. The strapping must be securely fastened to structural framing spaced no greater than 16 in. O.C. (406 mm) with a minimum nail penetration of 1-1/2 in. (38.1 mm) and a maximum nail spacing no greater than the width of the siding.

Louisiana-Pacific will assume no responsibility for any damage or condition arising from the use of rigid foam or exterior gypsum.

## BUTT JOINTS

Figure 2

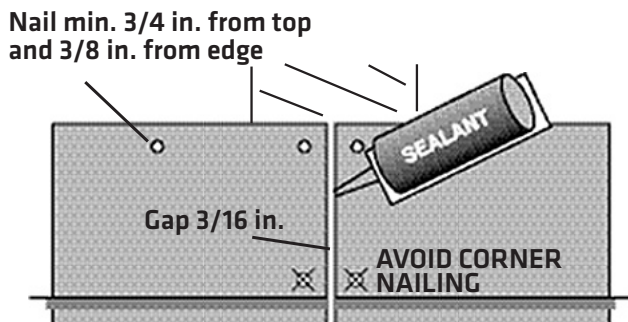

- Joints must occur over studs.
- A minimum 3/16 in. gap is required at ALL butt joints.
- If joint caulking option is selected, seal all gaps at butt joints with a high-quality exterior sealant meeting the ASTM C920, minimum Class 25 sealant.
- If joint moulding option is selected, add the thickness of the web to the gap allowing a net 3/16 in. space for expansion.
- If siding is prefinished by an approved or preferred prefinisher it does not require sealant or joint moulding when backed with minimum 4 in. wide flashing and the ends of the siding are factory finished.

LP 120 Series Foundation Lap sidings may be installed as exterior siding in Wildland Urban Interface (WUI) applications installed over one layer of 5/8" Type-X gypsum sheathing applied behind the exterior covering or cladding on the exterior side of the framing. They may also be installed over the exterior portion of a 1-hour fire-resistive exterior wall assembly designed for exterior fire exposure including assemblies using the gypsum panel and sheathing products listed in the Gypsum Association Fire Resistance Design Manual.

The Louisiana-Pacific Corporation ("LP") LP SmartSide Siding (the "Products") limited warranty (the "Warranty") applies only to structures on which the Products have been applied, finished and maintained in accordance with the published application, finishing and maintenance instructions in effect at the time of application. The failure to follow such application, finishing or maintenance instructions will void the Warranty as to the portion of the Products affected by the variance (the "Affected Products").

LP assumes no liability for any loss or damage sustained by the Affected Products and is expressly released by the purchaser or owner from any such loss or liability.

Any modification of the Warranty's application, finishing or maintenance requirements is void and unenforceable unless approved in writing prior to application by the Siding General Manager or his designee and a member of the LP Legal Department.

For a copy of the warranty or for installation and technical support, visit the LP SmartSide product support Web site at:

[www.lpsmartside.com](http://www.lpsmartside.com)

or for additional support call 800-450-6106.

**WARRANTY REMEDIES ARE NOT AVAILABLE IF REQUIREMENTS ARE NOT FOLLOWED.**

**Cal. Prop 65 Warning: Use of this product may result in exposure to wood dust, known to the State of California to cause cancer.**



© 2014 Louisiana-Pacific Corporation. All rights reserved. LP and SmartSide are registered trademarks of Louisiana-Pacific Corporation. Printed in U.S.A.

NOTE: Louisiana-Pacific Corporation periodically updates and revises its product information. To verify that this version is current, call 800-450-6106. LPZB0510 1/14

Figure 1

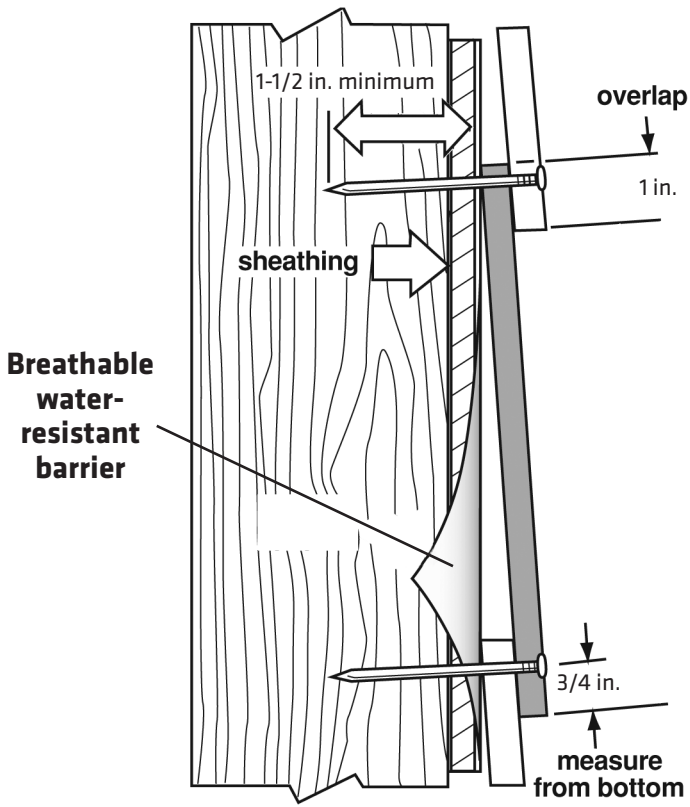

Figure 2

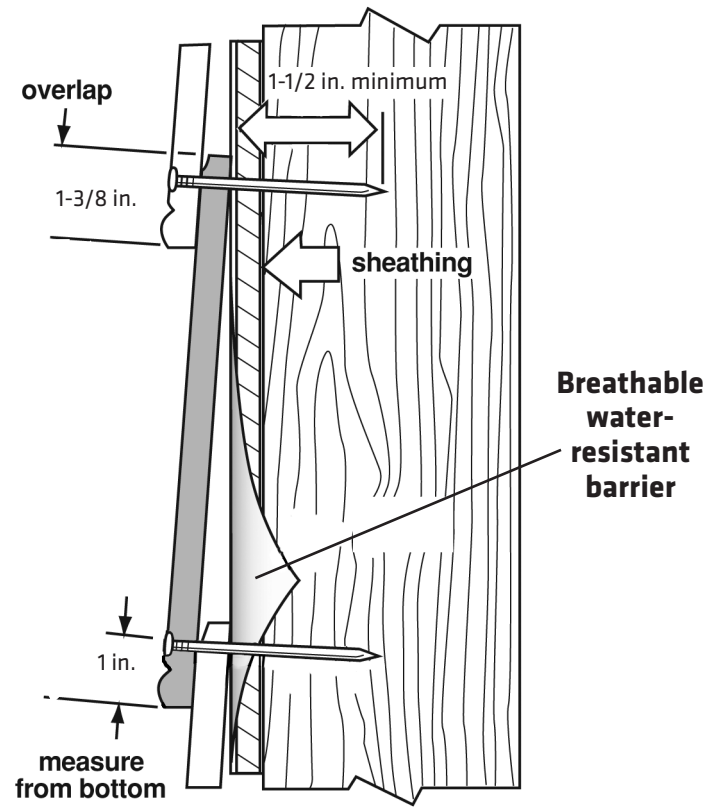
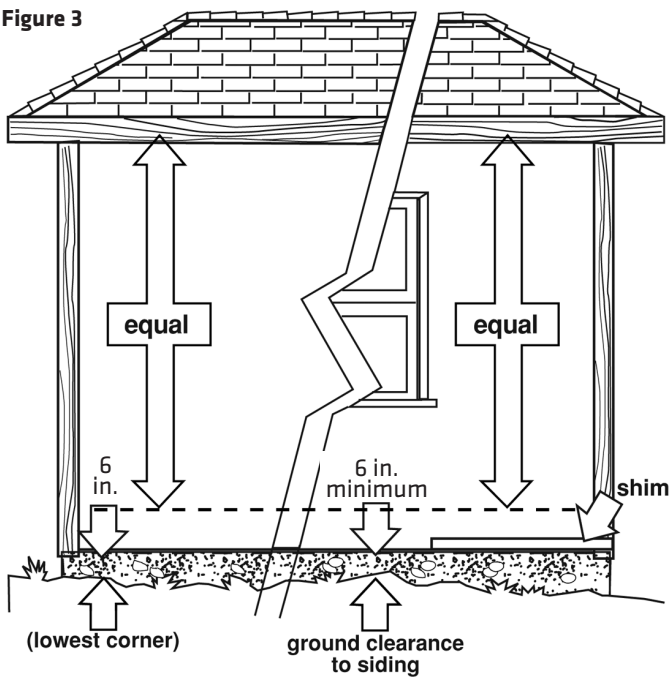
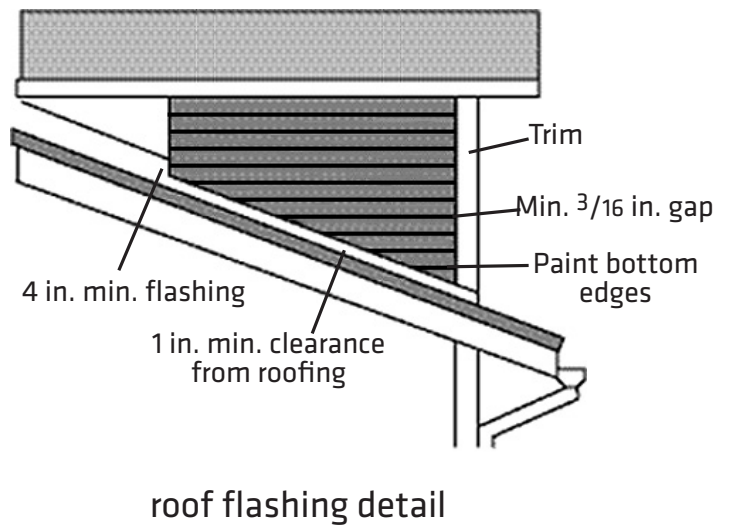

Figure 3



establish straight reference lines

Figure 4



# Over Openings

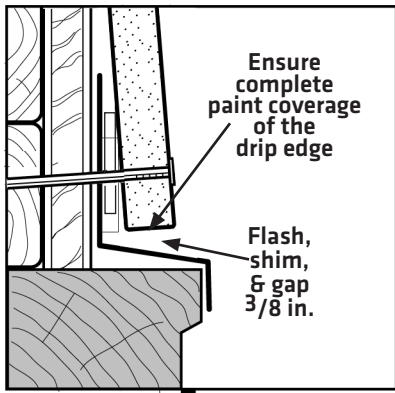

Figure 5A

# Alternate Butt Joint Treatments

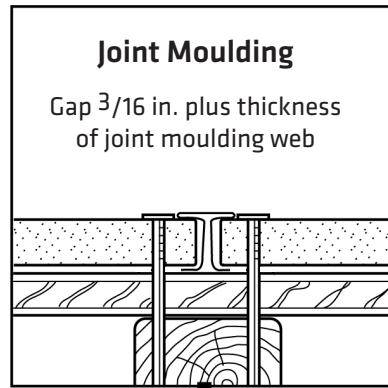

Figure 5B

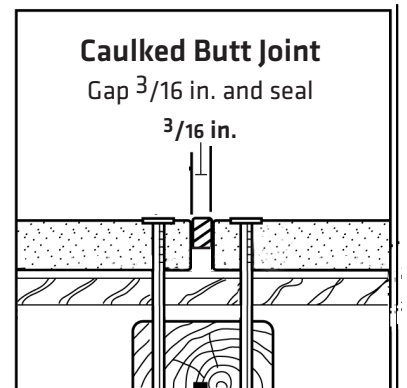

Figure 5C

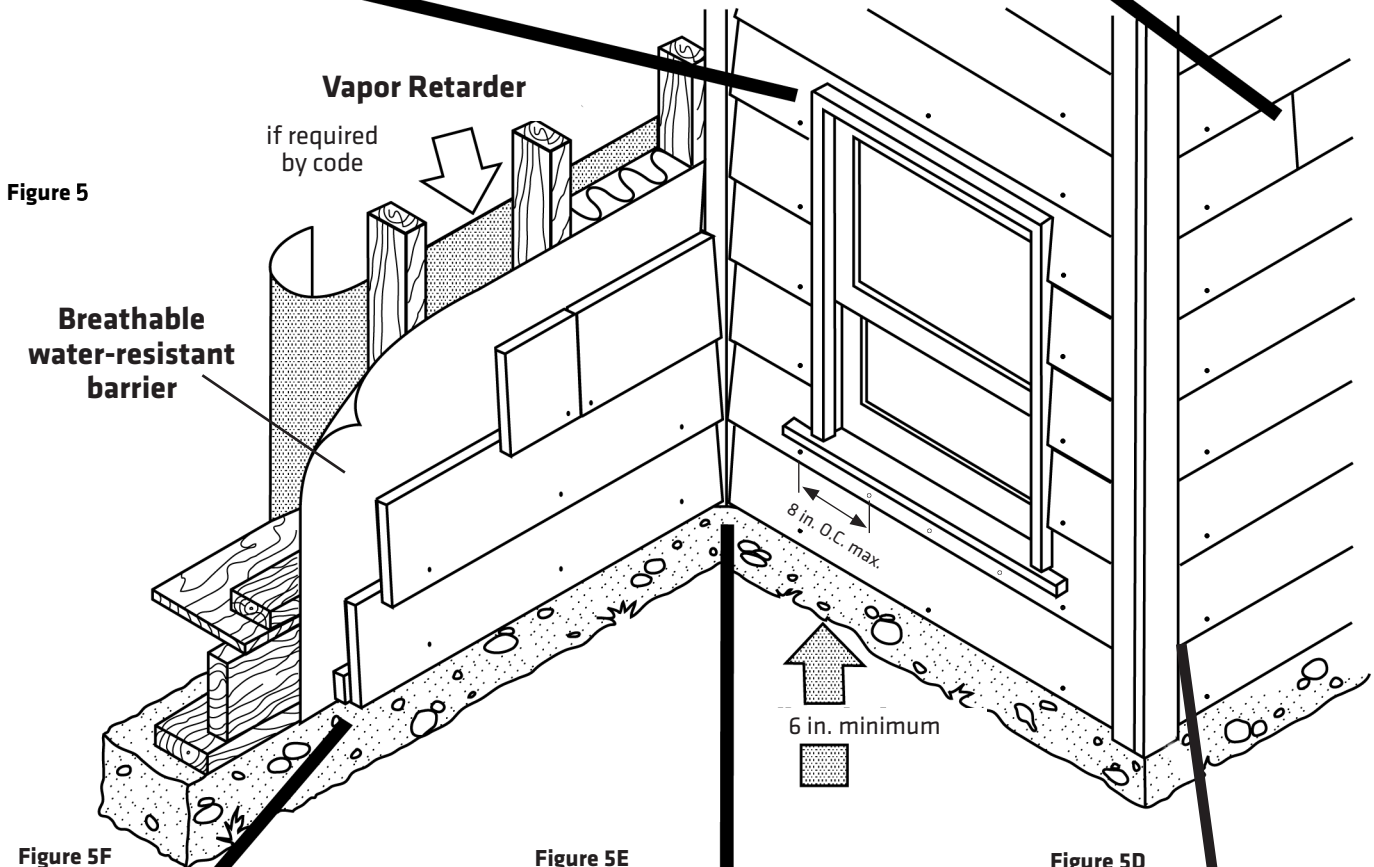

Figure 5

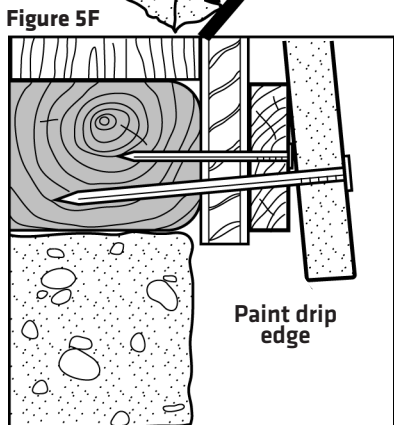

Figure 5F

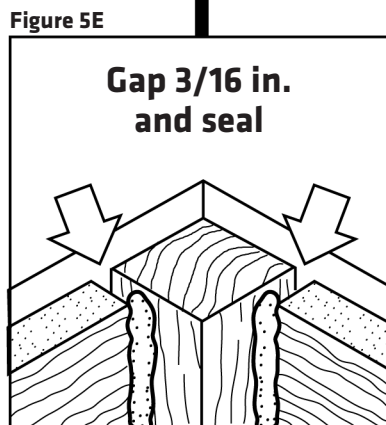

Figure 5E

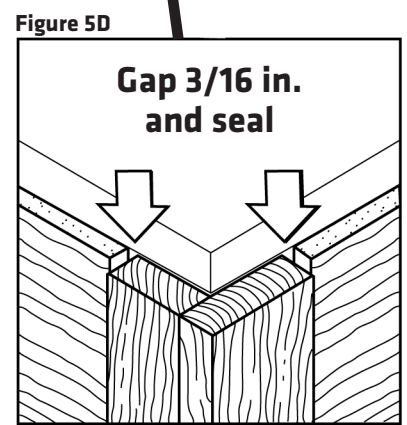

Figure 5D

**Bottom Course Detail**

**Inside Corner Detail**

**Outside Corner Detail**