

LP SOLIDSTART LVL BEAM & HEADER CANADIAN (LSD) TECHNICAL GUIDE

2.0E

Introduction

Designed to Outperform Traditional Lumber

LP® SolidStart® Laminated Veneer Lumber (LVL) is a vast improvement over traditional lumber. Problems that naturally occur as sawn lumber dries – twisting, splitting, checking, crowning and warping – are greatly reduced.

THE STRENGTH IS IN THE ENGINEERING

LP SolidStart LVL is made from ultrasonically and visually graded veneers arranged in a specific pattern to maximize the strength and stiffness of the veneers and to disperse the naturally occurring characteristics of wood, such as knots, that can weaken a sawn lumber beam. The veneers are then bonded with waterproof adhesives under pressure and heat. LP SolidStart LVL beams are exceptionally strong, solid and straight, making them excellent for most primary load-carrying beam applications.

LP SOLIDSTART LVL: AVAILABLE GRADES AND SIZES

LP SolidStart LVL is available in a range of depths and lengths, and is available in standard thicknesses of 1-3/4" and 3-1/2". The 2.0E LVL is also available in factory-laminated thicknesses (known as "billet beam") of 5-1/4" and 7" to eliminate the need for field nailing and/or bolting of multiple plies. In addition, a water-resistant coating called SiteCote™ is available for extra weather protection during construction. Please verify availability with the LP SolidStart Engineered Wood Products distributor in your area before specifying these products.

LIFETIME LIMITED WARRANTY

LP SolidStart Engineered Wood Products are backed by a lifetime limited warranty. Visit LPCorp.com or call 1.888.820.0325 for a copy of the warranty.

SOFTWARE FOR EASY, RELIABLE DESIGN

Our design/specification software enhances your in-house design capabilities. It offers accurate designs for a wide variety of applications with interfaces for printed output or plotted drawings. Through our distributors, we offer component design review services for designs using LP SolidStart Engineered Wood Products.

CODE EVALUATION

LP SolidStart Laminated Veneer Lumber has been evaluated by CCMC for compliance with the National Building Code of Canada. Contact your local LP SolidStart Engineered Wood Products distributor or visit LPCorp.com for the most current code reports.

- CCMC Evaluation Report 11518-R
- APA Product Report® PR-L280C

SUSTAINABLE

LP Building Products uses logs from SFI® certified forest management and fiber sourcing systems to help ensure that our entire wood supply comes from well managed forests and non-controversial sources. Virtually the entire log is used in the manufacturing process, and wood waste is repurposed or used to help fuel our mills. LP Engineered Wood Products also reduce construction waste on the job site.



Good for you. Good for our forests.
www.sfiprogram.org
SFI-00003

IMPORTANT NOTES

1. LP SolidStart LVL shall be designed for dry-use conditions only. Dry-use applies to products installed in dry, covered and well ventilated interior conditions in which the equivalent average moisture content in lumber will not exceed 15% nor a maximum of 19%.
2. This guide is valid only for LP SolidStart LVL members supporting loads applied parallel to the face of the veneer ("edge" orientation).
3. The tables in this guide meet the design requirements of the National Building Code of Canada for Limit States Design and assume a normal importance category. Ensure that the specified design loads, duration of load increases and deflection limits that you use to select products from this guide are appropriate for your application and comply with local code requirements. If you do not know the correct design criteria and all the loads imposed on the component from all parts of the structure, seek qualified help from the architect, engineer or designer of the structure. Additional reference data on wood construction is available in the form of building codes, code evaluation reports and other design references.
4. The Quick Reference and Uniform Load Resistance (PLF) tables in this guide are only for uniform loads on simple (single) or equal, continuous (multiple) span members as noted in each table. For other conditions such as concentrated loads, unequal spans, etc., contact your LP SolidStart distributor.
5. Beam spans in this guide are typically measured from center-to-center of supports except for door and window headers. A structurally adequate bearing surface under the full width (thickness) of the member must be provided at each support.
6. Minimum bearing length is 1-1/2" (at least one jack stud or cripple is required unless otherwise noted for a specific table. Refer to the Factored Reaction Resistance chart and the notes for each table. Verify local code requirements for minimum bearing).
7. Total load deflections are based on instantaneous loading. Long term deflection (creep) under sustained load has not been considered.
8. Vibration has not been considered in this guide. If LP SolidStart LVL is used as a floor joist, the designer shall perform the required vibration control checks.
9. LP SolidStart LVL is not cambered.
10. Higher grades of LP SolidStart LVL can be substituted for the indicated grade.
11. LP SolidStart LVL sized with the tables and design values in this guide requires continuous lateral restraint of the compression edge. Continuous restraint is defined as a maximum unbraced length of 24". This restraint is normally provided by sheathing and/or other framing members, which shall be adequately anchored to the LVL and the supporting structure. Framing conditions that do not provide continuous lateral restraint require special design. Contact your LP SolidStart Engineered Wood Products distributor. Caution: Failure to provide adequate lateral restraint could result in an unstable member and reduce its load capacity.
12. Lateral restraint shall also be provided at all supports to prevent rotation or twisting.
13. Refer to the Connection Details page for information on designing nailed and bolted connections, minimum nail spacing and end distances, and for properly connecting multiple plies of LVL to form a built-up member.

Table of Contents



2.0E LVL

Product Specifications & Design Values 4

Quick Reference Tables:

Floor Loading 5

Combined Roof and Floor Loading. 6-7

Roof Loading 8-9

Uniform Floor Load (PLF) Resistance Tables 10

Uniform Roof Load (PLF) Resistance Tables 11

GENERAL INFORMATION

Temporary Bracing & Warnings 12

Installation Details 13

Connection of Multiple Ply Beams 14

Fastener Design and Fastener & Load Orientation 15

Handling & Storage Guidelines 16

Product Specifications & Design Values

SPECIFIED STRENGTHS & STIFFNESS (PSI)					
Grade	Bending f_b^1	Modulus of Elasticity E^2 ($\times 10^6$ PSI)	Shear f_v	Compression	
				f_c (Parallel To Grain)	f_{cp} (Perpendicular To Grain)
2900F _v -2.0E	5359	2.0	530	5107	1365

NOTES:

- LP SolidStart LVL shall be designed for dry-use conditions only. Dry-use applies to products installed in dry, covered and well ventilated interior conditions in which the equivalent average moisture content in lumber will not exceed a yearly average of 15% and does not exceed 19% at any time.
- The specified strengths and stiffness are for standard load duration. Specified strengths shall be adjusted according to code. Stiffness shall not be adjusted.
- The specified strengths and stiffness are for members supporting loads applied parallel to the wide face ("edge" or "beam" orientation).
- The specified Bending strength, f_b , is tabulated for 12" depth. For depths greater than 12", multiply f_b by $(12/\text{depth})^{0.143}$. For depths less than 12", multiply f_b by $(12/\text{depth})^{0.011}$. For depths less than 3-1/2", multiply f_b by 1.147.
- Deflection calculations shall include both bending and shear deformations.

$$\text{Deflection for a simple span, uniform load: } \Delta = \frac{270wL^4}{Ebd^3} + \frac{28.8wL^2}{Ebd}$$

Where: Δ = deflection (in) E = modulus of elasticity (from table)
 w = uniform load (plf) b = width (in)
 L = design span (ft) d = depth (in)

Equations for other conditions can be found in engineering references.

SECTION PROPERTIES AND FACTORED RESISTANCES

Depth	Weight (lb/ft)				Factored Moment ² (lb-ft)				Factored Shear (lb)				Moment of Inertia (in ⁴)			
	1-3/4"	3-1/2"	5-1/4"	7"	1-3/4"	3-1/2"	5-1/4"	7"	1-3/4"	3-1/2"	5-1/4"	7"	1-3/4"	3-1/2"	5-1/4"	7"
7-1/4"	3.6	7.3	10.9	14.5	6516	13033	19549	26065	4035	8069	12104	16139	56	111	167	222
9-1/4"	4.6	9.3	13.9	18.5	10324	20649	30973	41297	5148	10295	15443	20591	115	231	346	462
9-1/2"	4.8	9.5	14.3	19.0	10858	21716	32573	43431	5287	10574	15860	21147	125	250	375	500
11-1/4"	5.6	11.3	16.9	22.5	14943	29887	44830	59773	6261	12521	18782	25043	208	415	623	831
11-7/8"	5.9	11.9	17.8	23.8	16550	33100	49651	66201	6608	13217	19825	26434	244	488	733	977
14"	7.0	14.0	21.0	28.0	22476	44952	67427	89903	7791	15582	23373	31164	400	800	1201	1601
16"	8.0	16.0	24.0	32.0	28801	57602	86403	115203	8904	17808	26712	35616	597	1195	1792	2389
18"	9.0	18.0	27.0	36.1	35842	71685	107527	143369	10017	20034	30051	40068	851	1701	2552	3402
20"	10.0	20.0	30.0	40.1	43588	87176	130764	174352	11130	22260	33390	44520	1167	2333	3500	4667
24"	12.0	24.0	36.1	48.1	61151	122303	183454	244606	13356	26712	40068	53424	2016	4032	6048	8064

NOTES:

- The Factored Moment and Shear are for standard load duration and shall be adjusted according to code.
- The tabulated Factored Moment Resistance assumes continuous lateral support of the compression edge. For other conditions, multiply the Factored Moment Resistance by the beam lateral stability factor, K_L , as defined in the CSA O86.
- The 3-1/2", 5-1/4" and 7" beam widths listed above can be either a single piece or a combination of widths. For example, a 7" wide beam may be a single billet beam of 7", two plies of 3-1/2", a single 1-3/4" attached to a 5-1/4" billet beam, a 3-1/2" with a 1-3/4" ply attached to each face, or four plies of 1-3/4". Refer to the Connection Assemblies details on page 14 for additional information.
- The tabulated weight is an estimate and shall only be used for design purposes. Contact LP for actual shipping weights.

FASTENERS:

Refer to pages 14-15 for information on connecting multiple plies and for the equivalent specific gravity for design of nailed and bolted connections.

FACTORED REACTION RESISTANCE (LBS)

Width	Bearing Length																					
	1-1/2"	2"	2-1/2"	3"	3-1/2"	4"	4-1/2"	5"	5-1/2"	6"	6-1/2"	7"	7-1/2"	8"	8-1/2"	9"	9-1/2"	10"	10-1/2"	11"	11-1/2"	12"
1-3/4"	2866	3822	4777	5733	6688	7644	8599	9555	10510	11466	12421	13377	14332	15288	16243	17199	18154	19110	20065	21021	21976	22932
3-1/2"	5733	7644	9555	11466	13377	15288	17199	19110	21021	22932	24843	26754	28665	30576	32487	34398	36309	38220	40131	42042	43953	45864
5-1/4"	8599	11466	14332	17199	20065	22932	25798	28665	31531	34398	37264	40131	42997	45864	48730	51597	54463	57330	60196	63063	65929	68796
7"	11466	15288	19110	22932	26754	30576	34398	38220	42042	45864	49686	53508	57330	61152	64974	68796	72618	76440	80262	84084	87906	91728

NOTES:

- Tabulated values are based on the factored compression resistance, perpendicular-to-grain, of the LVL. This is suitable for beams bearing on steel or the end-grain of studs.
- Verify that the support for the beam is structurally adequate to carry the reaction. The compressive resistance, parallel-to-grain, of studs may require more studs than the bearing length above indicates.
- For beams bearing on wood plates, the required bearing length will increase based on the bearing resistance (compression perpendicular-to-grain) of the species and grade used for the plate material.
- Verify local code requirements concerning minimum bearing.

Quick Reference Tables: Beam with Floor Loading

TO USE:

1. Select the correct table for the supported floor joist condition (simple or continuous).
2. Choose the required center-to-center span for the beam in the Span column.
3. Select the span carried by the beam across the top of the table.
4. Read the beam size or choice of beam sizes from the table.

EXAMPLE: A beam with a 16' span carries 15'-0" simple span joists on each side.

SOLUTION: Using the Simple-Span Floor Joists table with 30'-0" span carried, select either **3-1/2" x 16"** or **5-1/4" x 14"**.

NOTE: The 3-1/2" x 16" requires 7-1/2" intermediate bearing if a multiple span beam.

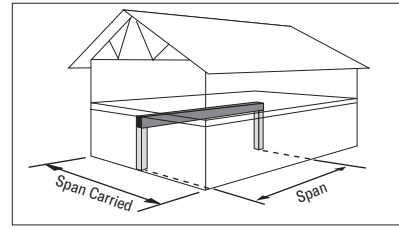

CONTINUOUS FLOOR JOISTS (SPECIFIED FLOOR LOADS: 40 PSF LIVE LOAD, 15 PSF DEAD LOAD)

Span	Beam Width	Span Carried By Beam											
		20'	22'	24'	26'	28'	30'	32'	34'	36'	38'	40'	
6'-0"	3-1/2"	7-1/4"	7-1/4"	7-1/4"	7-1/4"	7-1/4"	7-1/4"	7-1/4"	7-1/4"	7-1/4"	7-1/4"	7-1/4"	7-1/4"
	5-1/4"	7-1/4"	7-1/4"	7-1/4"	7-1/4"	7-1/4"	7-1/4"	7-1/4"	7-1/4"	7-1/4"	7-1/4"	7-1/4"	7-1/4"
8'-0"	3-1/2"	7-1/4"	7-1/4"	9-1/4"	9-1/4"	9-1/4"	9-1/4"	9-1/4"	9-1/4"	9-1/4"	9-1/4"	9-1/4"	9-1/4"
	5-1/4"	7-1/4"	7-1/4"	7-1/4"	7-1/4"	7-1/4"	7-1/4"	7-1/4"	7-1/4"	7-1/4"	7-1/4"	7-1/4"	7-1/4"
10'-0"	3-1/2"	9-1/4"	9-1/4"	9-1/4"	9-1/2"	11-1/4"	11-1/4"	11-1/4"	11-1/4"	11-1/4"	11-1/4"	11-1/4"	11-1/4"
	5-1/4"	9-1/4"	9-1/4"	9-1/4"	9-1/4"	9-1/4"	9-1/4"	9-1/4"	9-1/4"	9-1/4"	9-1/4"	9-1/2"	9-1/2"
12'-0"	3-1/2"	11-1/4"	11-1/4"	11-1/4"	11-1/4"	11-7/8"	11-7/8"	14"	14"	14"	14"	-	-
	5-1/4"	9-1/4"	9-1/4"	9-1/2"	11-1/4"	11-1/4"	11-1/4"	11-1/4"	11-1/4"	11-1/4"	11-1/4"	11-1/4"	11-1/4"
14'-0"	3-1/2"	14"	14"	14"	14"	14"	14"	16"	-	-	-	-	-
	5-1/4"	11-1/4"	11-1/4"	11-1/4"	11-7/8"	11-7/8"	14"	14"	14"	14"	14"	14"	14"
16'-0"	3-1/2"	14"	16"	16"	16"	16"	-	-	-	-	-	-	-
	5-1/4"	11-7/8"	14"	14"	14"	14"	14"	14"	14"	16"	16"	16"	16"
18'-0"	3-1/2"	16"	16"	18"	-	-	-	-	-	-	-	-	-
	5-1/4"	14"	14"	16"	16"	16"	16"	16"	16"	16"	16"	16"	18"
20'-0"	3-1/2"	18"	18"	-	-	-	-	-	-	-	-	-	-
	5-1/4"	16"	16"	16"	16"	18"	18"	18"	18"	18"	18"	18"	-
22'-0"	3-1/2"	-	-	-	-	-	-	-	-	-	-	-	-
	5-1/4"	18"	18"	18"	18"	18"	18"	-	-	-	-	-	-
24'-0"	3-1/2"	-	-	-	-	-	-	-	-	-	-	-	-
	5-1/4"	18"	18"	-	-	-	-	-	-	-	-	-	-

SIMPLE-SPAN FLOOR JOISTS (SPECIFIED FLOOR LOADS: 40 PSF LIVE LOAD, 15 PSF DEAD LOAD)

Span	Beam Width	Span Carried By Beam											
		20'	22'	24'	26'	28'	30'	32'	34'	36'	38'	40'	
6'-0"	3-1/2"	7-1/4"	7-1/4"	7-1/4"	7-1/4"	7-1/4"	7-1/4"	7-1/4"	7-1/4"	7-1/4"	7-1/4"	7-1/4"	7-1/4"
	5-1/4"	7-1/4"	7-1/4"	7-1/4"	7-1/4"	7-1/4"	7-1/4"	7-1/4"	7-1/4"	7-1/4"	7-1/4"	7-1/4"	7-1/4"
8'-0"	3-1/2"	7-1/4"	7-1/4"	7-1/4"	7-1/4"	7-1/4"	9-1/4"	9-1/4"	9-1/4"	9-1/4"	9-1/4"	9-1/4"	9-1/4"
	5-1/4"	7-1/4"	7-1/4"	7-1/4"	7-1/4"	7-1/4"	7-1/4"	7-1/4"	7-1/4"	7-1/4"	7-1/4"	7-1/4"	7-1/4"
10'-0"	3-1/2"	9-1/4"	9-1/4"	9-1/4"	9-1/4"	9-1/4"	9-1/4"	9-1/4"	9-1/2"	11-1/4"	11-1/4"	11-1/4"	11-1/4"
	5-1/4"	7-1/4"	7-1/4"	9-1/4"	9-1/4"	9-1/4"	9-1/4"	9-1/4"	9-1/4"	9-1/4"	9-1/4"	9-1/4"	9-1/4"
12'-0"	3-1/2"	9-1/2"	11-1/4"	11-1/4"	11-1/4"	11-1/4"	11-1/4"	11-1/4"	11-7/8"	11-7/8"	11-7/8"	14"	-
	5-1/4"	9-1/4"	9-1/4"	9-1/4"	9-1/4"	9-1/2"	9-1/2"	11-1/4"	11-1/4"	11-1/4"	11-1/4"	11-1/4"	11-1/4"
14'-0"	3-1/2"	11-1/4"	11-7/8"	11-7/8"	14"	14"	14"	14"	14"	14"	14"	14"	14"
	5-1/4"	11-1/4"	11-1/4"	11-1/4"	11-1/4"	11-1/4"	11-1/4"	11-7/8"	11-7/8"	11-7/8"	11-7/8"	11-7/8"	11-7/8"
16'-0"	3-1/2"	14"	14"	14"	14"	16"	16"	16"	16"	16"	-	-	-
	5-1/4"	11-1/4"	11-7/8"	11-7/8"	14"	14"	14"	14"	14"	14"	14"	14"	14"
18'-0"	3-1/2"	16"	16"	16"	16"	16"	16"	18"	18"	-	-	-	-
	5-1/4"	14"	14"	14"	14"	14"	14"	16"	16"	16"	16"	16"	16"
20'-0"	3-1/2"	16"	18"	18"	18"	18"	18"	-	-	-	-	-	-
	5-1/4"	14"	16"	16"	16"	16"	16"	16"	16"	16"	18"	18"	18"
22'-0"	3-1/2"	18"	18"	-	-	-	-	-	-	-	-	-	-
	5-1/4"	16"	16"	16"	16"	18"	18"	18"	18"	18"	18"	18"	18"
24'-0"	3-1/2"	-	-	-	-	-	-	-	-	-	-	-	-
	5-1/4"	18"	18"	18"	18"	18"	18"	-	-	-	-	-	-

NOTES:

1. Use the Continuous Floor Joists table where the floor joists are continuous (multiple span) over the beam. Use the Simple-Span Floor Joists table where the floor joists frame into the side of or end on top of the beam.
2. Span is center-to-center of supports and is valid for simple and equal, continuous beam spans.
3. End supports require 3" bearing. Interior supports require 6" bearing except 7-1/2" is required where **bold**. The bearing length is based on the compressive resistance, perpendicular-to-grain, of the LVL. See the Factored Reaction Resistance table on page 4 for additional information.
4. Deflections are limited to L/360 live load and L/240 total load.
5. Beam width can be either a single piece of LVL or built up from multiple plies that are nailed, bolted or connected with other approved fasteners. Refer to pages 14-15 for connection details.
6. Do not use where marked "-".

FLOOR BEAM QUICK REFERENCE DETAILS

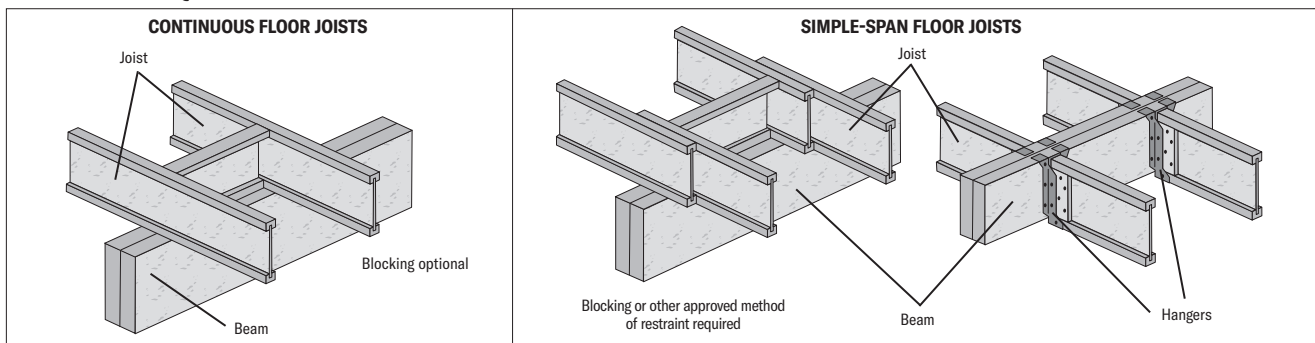

Quick Reference Tables: Beam with Combined Loading

TO USE:

1. Select the correct table for the roof loads needed.
2. Choose the required center-to-center span for the beam in the Span column.
3. Select the span carried by the beam across the top of the table.
4. Read the beam size or choice of beam sizes from the table.

EXAMPLE: A beam with a 9'-6" span supports a 32'-0" span carried for a 20 psf Roof Live Load.

SOLUTION: Using the correct table for the roof load with 32'-0" span carried, select either **3-1/2" x 11-1/4"** or **5-1/4" x 9-1/4"**.

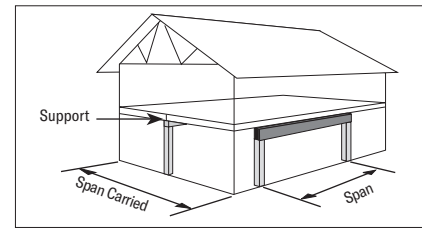

Span	Beam Width	Span Carried By Beam											
		20'	22'	24'	26'	28'	30'	32'	34'	36'	38'	40'	
6'-0"	3-1/2"	7-1/4"	7-1/4"	7-1/4"	7-1/4"	7-1/4"	7-1/4"	7-1/4"	7-1/4"	7-1/4"	7-1/4"	7-1/4"	7-1/4"
	5-1/4"	7-1/4"	7-1/4"	7-1/4"	7-1/4"	7-1/4"	7-1/4"	7-1/4"	7-1/4"	7-1/4"	7-1/4"	7-1/4"	7-1/4"
8'-0"	3-1/2"	7-1/4"	7-1/4"	9-1/4"	9-1/4"	9-1/4"	9-1/4"	9-1/4"	9-1/4"	9-1/4"	9-1/4"	9-1/4"	9-1/4"
	5-1/4"	7-1/4"	7-1/4"	7-1/4"	7-1/4"	7-1/4"	7-1/4"	7-1/4"	7-1/4"	7-1/4"	9-1/4"	9-1/4"	9-1/4"
9'-6"	3-1/2"	9-1/4"	9-1/4"	9-1/4"	9-1/4"	9-1/4"	9-1/2"	11-1/4"	11-1/4"	11-1/4"	11-1/4"	11-1/4"	11-1/4"
	5-1/4"	7-1/4"	9-1/4"	9-1/4"	9-1/4"	9-1/4"	9-1/4"	9-1/4"	9-1/4"	9-1/4"	9-1/4"	9-1/4"	9-1/4"
10'-0"	3-1/2"	9-1/4"	9-1/4"	9-1/4"	9-1/2"	11-1/4"	11-1/4"	11-1/4"	11-1/4"	11-1/4"	11-1/4"	11-1/4"	11-1/4"
	5-1/4"	9-1/4"	9-1/4"	9-1/4"	9-1/4"	9-1/4"	9-1/4"	9-1/4"	9-1/4"	9-1/4"	9-1/4"	9-1/4"	9-1/2"
12'-0"	3-1/2"	11-1/4"	11-1/4"	11-1/4"	11-7/8"	11-7/8"	11-7/8"	14"	14"	14"	14"	14"	14"
	5-1/4"	9-1/4"	9-1/2"	11-1/4"	11-1/4"	11-1/4"	11-1/4"	11-1/4"	11-1/4"	11-1/4"	11-1/4"	11-1/4"	11-1/4"
14'-0"	3-1/2"	14"	14"	14"	14"	14"	14"	16"	16"	16"	16"	16"	16"
	5-1/4"	11-1/4"	11-1/4"	11-1/4"	11-7/8"	11-7/8"	14"	14"	14"	14"	14"	14"	14"
16'-0"	3-1/2"	16"	16"	16"	16"	16"	16"	16"	18"	18"	18"	18"	18"
	5-1/4"	14"	14"	14"	14"	14"	14"	14"	16"	16"	16"	16"	16"
16'-6"	3-1/2"	16"	16"	16"	-	-	-	-	-	-	-	-	-
	5-1/4"	14"	14"	14"	14"	14"	16"	16"	16"	16"	16"	16"	16"
18'-0"	3-1/2"	16"	18"	18"	18"	18"	18"	18"	-	-	-	-	-
	5-1/4"	14"	16"	16"	16"	16"	16"	16"	16"	16"	18"	18"	18"
18'-6"	3-1/2"	18"	18"	-	-	-	-	-	-	-	-	-	-
	5-1/4"	16"	16"	16"	16"	16"	16"	18"	18"	18"	-	-	-
20'-0"	3-1/2"	18"	-	-	-	-	-	-	-	-	-	-	-
	5-1/4"	16"	16"	18"	18"	18"	18"	18"	18"	-	-	-	-
22'-0"	3-1/2"	-	-	-	-	-	-	-	-	-	-	-	-
	5-1/4"	18"	18"	18"	-	-	-	-	-	-	-	-	-
24'-0"	3-1/2"	-	-	-	-	-	-	-	-	-	-	-	-
	5-1/4"	-	-	-	-	-	-	-	-	-	-	-	-

Span	Beam Width	Span Carried By Beam											
		20'	22'	24'	26'	28'	30'	32'	34'	36'	38'	40'	
6'-0"	3-1/2"	7-1/4"	7-1/4"	7-1/4"	7-1/4"	7-1/4"	7-1/4"	7-1/4"	7-1/4"	7-1/4"	7-1/4"	7-1/4"	7-1/4"
	5-1/4"	7-1/4"	7-1/4"	7-1/4"	7-1/4"	7-1/4"	7-1/4"	7-1/4"	7-1/4"	7-1/4"	7-1/4"	7-1/4"	7-1/4"
8'-0"	3-1/2"	9-1/4"	9-1/4"	9-1/4"	9-1/4"	9-1/4"	9-1/4"	9-1/4"	9-1/4"	9-1/4"	9-1/4"	9-1/4"	9-1/4"
	5-1/4"	7-1/4"	7-1/4"	7-1/4"	7-1/4"	7-1/4"	7-1/4"	9-1/4"	9-1/4"	9-1/4"	9-1/4"	9-1/4"	9-1/4"
9'-6"	3-1/2"	9-1/4"	9-1/4"	9-1/4"	9-1/2"	11-1/4"	11-1/4"	11-1/4"	11-1/4"	11-1/4"	11-1/4"	11-1/4"	11-1/4"
	5-1/4"	9-1/4"	9-1/4"	9-1/4"	9-1/4"	9-1/4"	9-1/4"	9-1/4"	9-1/4"	9-1/4"	9-1/4"	9-1/2"	9-1/2"
10'-0"	3-1/2"	9-1/4"	9-1/2"	11-1/4"	11-1/4"	11-1/4"	11-1/4"	11-1/4"	11-1/4"	11-1/4"	11-1/4"	11-1/4"	11-7/8"
	5-1/4"	9-1/4"	9-1/4"	9-1/4"	9-1/4"	9-1/4"	9-1/4"	9-1/4"	9-1/2"	9-1/2"	11-1/4"	11-1/4"	11-1/4"
12'-0"	3-1/2"	11-1/4"	11-7/8"	11-7/8"	14"	14"	14"	14"	14"	14"	14"	14"	14"
	5-1/4"	11-1/4"	11-1/4"	11-1/4"	11-1/4"	11-1/4"	11-1/4"	11-1/4"	11-1/4"	11-7/8"	11-7/8"	11-7/8"	11-7/8"
14'-0"	3-1/2"	14"	14"	14"	14"	16"	16"	16"	16"	16"	16"	16"	16"
	5-1/4"	11-1/4"	11-7/8"	11-7/8"	14"	14"	14"	14"	14"	14"	14"	14"	14"
16'-0"	3-1/2"	16"	16"	16"	16"	16"	16"	16"	16"	16"	16"	16"	16"
	5-1/4"	14"	14"	14"	14"	16"	16"	16"	16"	16"	16"	16"	16"
16'-6"	3-1/2"	16"	-	-	-	-	-	-	-	-	-	-	-
	5-1/4"	14"	14"	14"	16"	16"	16"	16"	16"	16"	16"	16"	16"
18'-0"	3-1/2"	18"	18"	18"	18"	-	-	-	-	-	-	-	-
	5-1/4"	16"	16"	16"	16"	16"	16"	18"	18"	18"	18"	18"	18"
18'-6"	3-1/2"	-	-	-	-	-	-	-	-	-	-	-	-
	5-1/4"	16"	16"	16"	16"	18"	18"	18"	18"	18"	18"	18"	18"
20'-0"	3-1/2"	-	-	-	-	-	-	-	-	-	-	-	-
	5-1/4"	18"	18"	18"	18"	18"	18"	18"	18"	18"	18"	18"	18"
22'-0"	3-1/2"	-	-	-	-	-	-	-	-	-	-	-	-
	5-1/4"	18"	18"	18"	18"	18"	18"	18"	18"	18"	18"	18"	18"
24'-0"	3-1/2"	-	-	-	-	-	-	-	-	-	-	-	-
	5-1/4"	-	-	-	-	-	-	-	-	-	-	-	-

NOTES:

1. Span is center-to-center of supports and is valid for simple beam spans only.
2. End supports require 3" bearing except 4-1/2" is required where **bold**. The end supports for the standard garage door spans of 9'-6", 16'-6" and 18'-6" are limited to 3" (two trimmers) on each end. The bearing length is based on the compressive resistance, perpendicular-to-grain, of the LVL. See the Factored Reaction Resistance table on page 4 for additional information.
3. Deflections are limited to L/360 live/snow load and L/240 total load.
4. Loads include 100 plf for an exterior wall and assume a 2' maximum overhang on the roof and an interior support at mid-span of the floor joists.
5. Beam width can be either a single piece of LVL or built up from multiple plies that are nailed, bolted or connected with other approved fasteners. Refer to pages 14-15 for connection details.
6. Do not use where marked "-".

Quick Reference Tables: Beam with Combined Loading

TO USE:

1. Select the correct table for the roof loads needed.
2. Choose the required center-to-center span for the beam in the Span column.
3. Select the span carried by the beam across the top of the table.
4. Read the beam size or choice of beam sizes from the table.

EXAMPLE: A beam with a 9'-6" span supports a 32'-0" span carried for a 40 psf Roof Snow load.

SOLUTION: Using the correct table for the roof load with 32'-0" span carried, select either **3-1/2" x 11-1/4"** or **5-1/4" x 9-1/4"**.

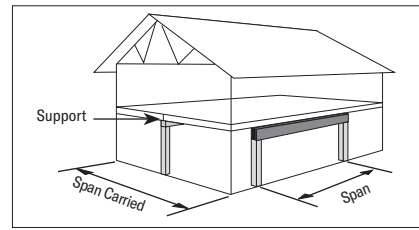

Span	Beam Width	Span Carried By Beam											
		20'	22'	24'	26'	28'	30'	32'	34'	36'	38'	40'	
6'-0"	3-1/2"	7-1/4"	7-1/4"	7-1/4"	7-1/4"	7-1/4"	7-1/4"	7-1/4"	7-1/4"	7-1/4"	7-1/4"	7-1/4"	7-1/4"
	5-1/4"	7-1/4"	7-1/4"	7-1/4"	7-1/4"	7-1/4"	7-1/4"	7-1/4"	7-1/4"	7-1/4"	7-1/4"	7-1/4"	7-1/4"
8'-0"	3-1/2"	9-1/4"	9-1/4"	9-1/4"	9-1/4"	9-1/4"	9-1/4"	9-1/4"	9-1/4"	9-1/4"	9-1/4"	9-1/2"	11-1/4"
	5-1/4"	7-1/4"	7-1/4"	7-1/4"	7-1/4"	9-1/4"	9-1/4"	9-1/4"	9-1/4"	9-1/4"	9-1/4"	9-1/4"	9-1/4"
9'-6"	3-1/2"	9-1/4"	9-1/2"	11-1/4"	11-1/4"	11-1/4"	11-1/4"	11-1/4"	11-1/4"	11-1/4"	-	-	-
	5-1/4"	9-1/4"	9-1/4"	9-1/4"	9-1/4"	9-1/4"	9-1/4"	9-1/4"	9-1/4"	9-1/2"	9-1/2"	11-1/4"	11-1/4"
10'-0"	3-1/2"	11-1/4"	11-1/4"	11-1/4"	11-1/4"	11-1/4"	11-1/4"	11-1/4"	11-1/4"	11-7/8"	11-7/8"	11-7/8"	14"
	5-1/4"	9-1/4"	9-1/4"	9-1/4"	9-1/4"	9-1/4"	9-1/4"	9-1/4"	11-1/4"	11-1/4"	11-1/4"	11-1/4"	11-1/4"
12'-0"	3-1/2"	11-7/8"	11-7/8"	14"	14"	14"	14"	14"	14"	14"	14"	16"	16"
	5-1/4"	11-1/4"	11-1/4"	11-1/4"	11-1/4"	11-1/4"	11-1/4"	11-7/8"	11-7/8"	14"	14"	14"	14"
14'-0"	3-1/2"	14"	14"	16"	16"	16"	16"	16"	16"	16"	18"	-	-
	5-1/4"	11-7/8"	14"	14"	14"	14"	14"	14"	14"	14"	14"	16"	16"
16'-0"	3-1/2"	16"	16"	18"	18"	18"	18"	18"	-	-	-	-	-
	5-1/4"	14"	14"	16"	16"	16"	16"	16"	16"	16"	16"	18"	18"
16'-6"	3-1/2"	-	-	-	-	-	-	-	-	-	-	-	-
	5-1/4"	14"	16"	16"	16"	16"	-	-	-	-	-	-	-
18'-0"	3-1/2"	18"	18"	-	-	-	-	-	-	-	-	-	-
	5-1/4"	16"	16"	16"	18"	18"	18"	18"	18"	18"	18"	-	-
18'-6"	3-1/2"	-	-	-	-	-	-	-	-	-	-	-	-
	5-1/4"	16"	16"	18"	18"	-	-	-	-	-	-	-	-
20'-0"	3-1/2"	-	-	-	-	-	-	-	-	-	-	-	-
	5-1/4"	18"	18"	18"	-	-	-	-	-	-	-	-	-
22'-0"	3-1/2"	-	-	-	-	-	-	-	-	-	-	-	-
	5-1/4"	-	-	-	-	-	-	-	-	-	-	-	-
24'-0"	3-1/2"	-	-	-	-	-	-	-	-	-	-	-	-
	5-1/4"	-	-	-	-	-	-	-	-	-	-	-	-

Span	Beam Width	Span Carried By Beam											
		20'	22'	24'	26'	28'	30'	32'	34'	36'	38'	40'	
6'-0"	3-1/2"	7-1/4"	7-1/4"	7-1/4"	7-1/4"	7-1/4"	7-1/4"	7-1/4"	7-1/4"	7-1/4"	9-1/4"	9-1/4"	9-1/4"
	5-1/4"	7-1/4"	7-1/4"	7-1/4"	7-1/4"	7-1/4"	7-1/4"	7-1/4"	7-1/4"	7-1/4"	7-1/4"	7-1/4"	7-1/4"
8'-0"	3-1/2"	9-1/4"	9-1/4"	9-1/4"	9-1/4"	9-1/4"	9-1/4"	9-1/2"	11-1/4"	11-1/4"	11-1/4"	11-1/4"	
	5-1/4"	7-1/4"	7-1/4"	9-1/4"	9-1/4"	9-1/4"	9-1/4"	9-1/4"	9-1/4"	9-1/4"	9-1/4"	9-1/4"	
9'-6"	3-1/2"	11-1/4"	11-1/4"	11-1/4"	11-1/4"	11-1/4"	11-1/4"	-	-	-	-	-	
	5-1/4"	9-1/4"	9-1/4"	9-1/4"	9-1/4"	9-1/4"	9-1/2"	11-1/4"	11-1/4"	11-1/4"	11-1/4"	11-1/4"	
10'-0"	3-1/2"	11-1/4"	11-1/4"	11-1/4"	11-1/4"	11-1/4"	11-1/4"	11-7/8"	11-7/8"	14"	14"	14"	
	5-1/4"	9-1/4"	9-1/4"	9-1/4"	9-1/4"	9-1/4"	11-1/4"	11-1/4"	11-1/4"	11-1/4"	11-1/4"	11-1/4"	
12'-0"	3-1/2"	14"	14"	14"	14"	14"	14"	14"	14"	14"	14"	14"	
	5-1/4"	11-1/4"	11-1/4"	11-1/4"	11-7/8"	11-7/8"	14"	14"	14"	14"	14"	14"	
14'-0"	3-1/2"	16"	16"	16"	16"	16"	18"	-	-	-	-	-	
	5-1/4"	14"	14"	14"	14"	14"	14"	16"	16"	16"	16"	16"	
16'-0"	3-1/2"	18"	18"	18"	18"	-	-	-	-	-	-	-	
	5-1/4"	14"	16"	16"	16"	16"	16"	18"	18"	18"	18"	18"	
16'-6"	3-1/2"	-	-	-	-	-	-	-	-	-	-	-	
	5-1/4"	16"	16"	16"	16"	-	-	-	-	-	-	-	
18'-0"	3-1/2"	-	-	-	-	-	-	-	-	-	-	-	
	5-1/4"	16"	18"	18"	18"	18"	18"	-	-	-	-	-	
18'-6"	3-1/2"	-	-	-	-	-	-	-	-	-	-	-	
	5-1/4"	18"	18"	-	-	-	-	-	-	-	-	-	
20'-0"	3-1/2"	-	-	-	-	-	-	-	-	-	-	-	
	5-1/4"	18"	-	-	-	-	-	-	-	-	-	-	
22'-0"	3-1/2"	-	-	-	-	-	-	-	-	-	-	-	
	5-1/4"	-	-	-	-	-	-	-	-	-	-	-	
24'-0"	3-1/2"	-	-	-	-	-	-	-	-	-	-	-	
	5-1/4"	-	-	-	-	-	-	-	-	-	-	-	

NOTES:

1. Span is center-to-center of supports and is valid for simple beam spans only.
2. End supports require 3" bearing except 4-1/2" is required where **bold**. The end supports for the standard garage door spans of 9'-6", 16'-6" and 18'-6" are limited to 3" (two trimmers) on each end. The bearing length is based on the compressive resistance, perpendicular-to-grain, of the LVL. See the Factored Reaction Resistance table on page 4 for additional information.
3. Deflections are limited to L/360 live/snow load and L/240 total load.
4. Loads include 100 plf for an exterior wall and assume a 2' maximum overhang on the roof and an interior support at mid-span of the floor joists.
5. Beam width can be either a single piece of LVL or built up from multiple plies that are nailed, bolted or connected with other approved fasteners. Refer to pages 14-15 for connection details.
6. Do not use where marked "-".

Quick Reference Tables: Beam with Roof Loading

TO USE:

1. Select the correct table for the roof loads needed.
2. Choose the required center-to-center span for the beam in the Span column.
3. Select the span carried by the beam across the top of the table.
4. Read the beam size or choice of beam sizes from the table.

EXAMPLE: A beam with a 16'-6" span supports a 36'-0" span carried for a 30 psf Roof Snow load.

SOLUTION: Using the correct table for the roof load with 36'-0" span carried, select either **3-1/2" x 16"** or **5-1/4" x 14"**.

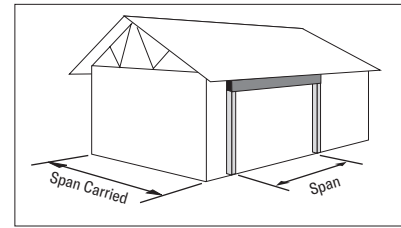

Span	Beam Width	Span Carried By Beam											
		20'	22'	24'	26'	28'	30'	32'	34'	36'	38'	40'	
6'-0"	3-1/2"	7-1/4"	7-1/4"	7-1/4"	7-1/4"	7-1/4"	7-1/4"	7-1/4"	7-1/4"	7-1/4"	7-1/4"	7-1/4"	7-1/4"
	5-1/4"	7-1/4"	7-1/4"	7-1/4"	7-1/4"	7-1/4"	7-1/4"	7-1/4"	7-1/4"	7-1/4"	7-1/4"	7-1/4"	7-1/4"
8'-0"	3-1/2"	7-1/4"	7-1/4"	7-1/4"	7-1/4"	7-1/4"	7-1/4"	7-1/4"	7-1/4"	7-1/4"	7-1/4"	7-1/4"	7-1/4"
	5-1/4"	7-1/4"	7-1/4"	7-1/4"	7-1/4"	7-1/4"	7-1/4"	7-1/4"	7-1/4"	7-1/4"	7-1/4"	7-1/4"	7-1/4"
9'-6"	3-1/2"	7-1/4"	7-1/4"	7-1/4"	7-1/4"	7-1/4"	9-1/4"	9-1/4"	9-1/4"	9-1/4"	9-1/4"	9-1/4"	9-1/4"
	5-1/4"	7-1/4"	7-1/4"	7-1/4"	7-1/4"	7-1/4"	9-1/4"	9-1/4"	9-1/4"	9-1/4"	9-1/4"	9-1/4"	9-1/4"
10'-0"	3-1/2"	7-1/4"	7-1/4"	9-1/4"	9-1/4"	9-1/4"	9-1/4"	9-1/4"	9-1/4"	9-1/4"	9-1/4"	9-1/4"	9-1/4"
	5-1/4"	7-1/4"	7-1/4"	7-1/4"	7-1/4"	7-1/4"	7-1/4"	7-1/4"	7-1/4"	7-1/4"	9-1/4"	9-1/4"	9-1/4"
12'-0"	3-1/2"	9-1/4"	9-1/4"	9-1/4"	9-1/4"	9-1/2"	11-1/4"	11-1/4"	11-1/4"	11-1/4"	11-1/4"	11-1/4"	11-1/4"
	5-1/4"	9-1/4"	9-1/4"	9-1/4"	9-1/4"	9-1/2"	9-1/2"	11-1/4"	11-1/4"	11-1/4"	11-1/4"	11-1/4"	11-1/4"
14'-0"	3-1/2"	11-1/4"	11-1/4"	11-1/4"	11-1/4"	11-1/4"	11-1/4"	11-1/4"	11-7/8"	11-7/8"	11-7/8"	14"	14"
	5-1/4"	9-1/4"	9-1/4"	9-1/4"	9-1/2"	9-1/2"	11-1/4"	11-1/4"	11-1/4"	11-1/4"	11-1/4"	11-1/4"	11-1/4"
16'-0"	3-1/2"	11-7/8"	11-7/8"	14"	14"	14"	14"	14"	14"	14"	14"	14"	14"
	5-1/4"	11-1/4"	11-1/4"	11-1/4"	11-1/4"	11-1/4"	11-1/4"	11-7/8"	11-7/8"	11-7/8"	14"	14"	14"
16'-6"	3-1/2"	11-7/8"	14"	14"	14"	14"	14"	14"	14"	14"	14"	16"	16"
	5-1/4"	11-1/4"	11-1/4"	11-1/4"	11-1/4"	11-1/4"	11-7/8"	11-7/8"	11-7/8"	14"	14"	14"	14"
18'-0"	3-1/2"	14"	14"	14"	14"	16"	16"	16"	16"	16"	16"	16"	16"
	5-1/4"	11-1/4"	11-7/8"	11-7/8"	14"	14"	14"	14"	14"	14"	14"	14"	14"
18'-6"	3-1/2"	14"	14"	14"	16"	16"	16"	16"	16"	16"	16"	16"	18"
	5-1/4"	11-7/8"	11-7/8"	14"	14"	14"	14"	14"	14"	14"	14"	14"	14"
20'-0"	3-1/2"	16"	16"	16"	16"	16"	16"	16"	18"	18"	18"	18"	18"
	5-1/4"	14"	14"	14"	14"	14"	14"	14"	16"	16"	16"	16"	16"
22'-0"	3-1/2"	16"	16"	18"	18"	18"	18"	18"	18"	-	-	-	-
	5-1/4"	14"	14"	16"	16"	16"	16"	16"	16"	16"	18"	18"	18"
24'-0"	3-1/2"	18"	18"	18"	-	-	-	-	-	-	-	-	-
	5-1/4"	16"	16"	16"	16"	18"	18"	18"	18"	18"	18"	18"	-

Span	Beam Width	Span Carried By Beam											
		20'	22'	24'	26'	28'	30'	32'	34'	36'	38'	40'	
6'-0"	3-1/2"	7-1/4"	7-1/4"	7-1/4"	7-1/4"	7-1/4"	7-1/4"	7-1/4"	7-1/4"	7-1/4"	7-1/4"	7-1/4"	7-1/4"
	5-1/4"	7-1/4"	7-1/4"	7-1/4"	7-1/4"	7-1/4"	7-1/4"	7-1/4"	7-1/4"	7-1/4"	7-1/4"	7-1/4"	7-1/4"
8'-0"	3-1/2"	7-1/4"	7-1/4"	7-1/4"	7-1/4"	7-1/4"	7-1/4"	7-1/4"	7-1/4"	7-1/4"	9-1/4"	9-1/4"	9-1/4"
	5-1/4"	7-1/4"	7-1/4"	7-1/4"	7-1/4"	7-1/4"	7-1/4"	7-1/4"	7-1/4"	7-1/4"	7-1/4"	7-1/4"	7-1/4"
9'-6"	3-1/2"	9-1/4"	9-1/4"	9-1/4"	9-1/4"	9-1/4"	9-1/4"	9-1/4"	9-1/4"	9-1/4"	9-1/4"	9-1/4"	9-1/4"
	5-1/4"	7-1/4"	7-1/4"	7-1/4"	7-1/4"	7-1/4"	7-1/4"	7-1/4"	7-1/4"	9-1/4"	9-1/4"	9-1/4"	9-1/4"
10'-0"	3-1/2"	9-1/4"	9-1/4"	9-1/4"	9-1/4"	9-1/4"	9-1/4"	9-1/4"	9-1/4"	9-1/4"	9-1/4"	9-1/2"	9-1/2"
	5-1/4"	7-1/4"	7-1/4"	7-1/4"	7-1/4"	7-1/4"	9-1/4"	9-1/4"	9-1/4"	9-1/4"	9-1/4"	9-1/4"	9-1/4"
12'-0"	3-1/2"	9-1/4"	9-1/4"	11-1/4"	11-1/4"	11-1/4"	11-1/4"	11-1/4"	11-1/4"	11-1/4"	11-1/4"	11-1/4"	11-7/8"
	5-1/4"	9-1/4"	9-1/4"	9-1/4"	9-1/4"	9-1/4"	9-1/4"	9-1/4"	9-1/4"	9-1/2"	11-1/4"	11-1/4"	11-1/4"
14'-0"	3-1/2"	11-1/4"	11-1/4"	11-7/8"	11-7/8"	11-7/8"	14"	14"	14"	14"	14"	14"	14"
	5-1/4"	9-1/2"	11-1/4"	11-1/4"	11-1/4"	11-1/4"	11-1/4"	11-1/4"	11-1/4"	11-1/4"	11-1/4"	11-7/8"	11-7/8"
16'-0"	3-1/2"	14"	14"	14"	14"	14"	14"	16"	16"	16"	16"	16"	16"
	5-1/4"	11-1/4"	11-1/4"	11-7/8"	11-7/8"	11-7/8"	14"	14"	14"	14"	14"	14"	14"
16'-6"	3-1/2"	14"	14"	14"	14"	14"	16"	16"	16"	16"	16"	16"	-
	5-1/4"	11-1/4"	11-7/8"	11-7/8"	14"	14"	14"	14"	14"	14"	14"	14"	14"
18'-0"	3-1/2"	16"	16"	16"	16"	16"	16"	16"	18"	18"	18"	18"	18"
	5-1/4"	14"	14"	14"	14"	14"	14"	14"	16"	16"	16"	16"	16"
18'-6"	3-1/2"	16"	16"	16"	16"	16"	18"	18"	18"	-	-	-	-
	5-1/4"	14"	14"	14"	14"	14"	14"	14"	16"	16"	16"	16"	16"
20'-0"	3-1/2"	16"	16"	18"	18"	18"	18"	18"	18"	-	-	-	-
	5-1/4"	14"	14"	16"	16"	16"	16"	16"	16"	16"	18"	18"	18"
22'-0"	3-1/2"	18"	18"	18"	-	-	-	-	-	-	-	-	-
	5-1/4"	16"	16"	16"	16"	18"	18"	18"	18"	18"	18"	18"	-
24'-0"	3-1/2"	-	-	-	-	-	-	-	-	-	-	-	-
	5-1/4"	18"	18"	18"	18"	18"	-	-	-	-	-	-	-

NOTES:

1. Span is center-to-center of supports and is valid for simple beam spans only.
2. End supports require 3" bearing except 4-1/2" is required where **bold**.
The end supports for the standard garage door spans of 9'-6", 16'-6" and 18'-6" are limited to 3" (two trimmers) on each end.
The bearing length is based on the compressive resistance, perpendicular-to-grain, of the LVL. See the Factored Reaction Resistance table on page 4 for additional information.
3. Deflections are limited to L/360 live/snow load and L/240 total load.
4. Loads assume a 2' maximum overhang on the roof.
5. Beam width can be either a single piece of LVL or built up from multiple plies that are nailed, bolted or connected with other approved fasteners.
Refer to pages 14-15 for connection details.
6. Do not use where marked "-".

Quick Reference Tables: Beam with Roof Loading

TO USE:

1. Select the correct table for the roof loads needed.
2. Choose the required center-to-center span for the beam in the Span column.
3. Select the span carried by the beam across the top of the table.
4. Read the beam size or choice of beam sizes from the table.

EXAMPLE: A beam with a 16'-6" span supports a 36'-0" span carried for a 50 psf Roof Snow load.

SOLUTION: Using the correct table for the roof load with 36'-0" span carried, select a **5-1/4" x 16"**.

NOTE: A 3-1/2" beam does not work.

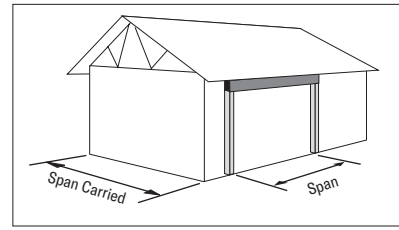

Span	Beam Width	Span Carried By Beam											
		20'	22'	24'	26'	28'	30'	32'	34'	36'	38'	40'	
6'-0"	3-1/2"	7-1/4"	7-1/4"	7-1/4"	7-1/4"	7-1/4"	7-1/4"	7-1/4"	7-1/4"	7-1/4"	7-1/4"	7-1/4"	7-1/4"
	5-1/4"	7-1/4"	7-1/4"	7-1/4"	7-1/4"	7-1/4"	7-1/4"	7-1/4"	7-1/4"	7-1/4"	7-1/4"	7-1/4"	7-1/4"
8'-0"	3-1/2"	7-1/4"	7-1/4"	7-1/4"	9-1/4"	9-1/4"	9-1/4"	9-1/4"	9-1/4"	9-1/4"	9-1/4"	9-1/4"	9-1/4"
	5-1/4"	7-1/4"	7-1/4"	7-1/4"	7-1/4"	7-1/4"	7-1/4"	7-1/4"	7-1/4"	7-1/4"	7-1/4"	7-1/4"	7-1/4"
9'-6"	3-1/2"	9-1/4"	9-1/4"	9-1/4"	9-1/4"	9-1/4"	9-1/4"	9-1/4"	9-1/4"	9-1/2"	11-1/4"	11-1/4"	11-1/4"
	5-1/4"	7-1/4"	7-1/4"	9-1/4"	9-1/4"	9-1/4"	9-1/4"	9-1/4"	9-1/4"	9-1/4"	9-1/4"	9-1/4"	9-1/4"
10'-0"	3-1/2"	9-1/4"	9-1/4"	9-1/4"	9-1/4"	9-1/2"	11-1/4"	11-1/4"	11-1/4"	11-1/4"	11-1/4"	11-1/4"	11-1/4"
	5-1/4"	9-1/4"	9-1/4"	9-1/4"	9-1/4"	9-1/4"	9-1/4"	9-1/4"	9-1/4"	9-1/4"	9-1/4"	9-1/4"	9-1/4"
12'-0"	3-1/2"	11-1/4"	11-1/4"	11-1/4"	11-1/4"	11-1/4"	11-7/8"	11-7/8"	14"	14"	14"	14"	14"
	5-1/4"	9-1/4"	9-1/4"	9-1/4"	9-1/2"	9-1/2"	11-1/4"	11-1/4"	11-1/4"	11-1/4"	11-1/4"	11-1/4"	11-1/4"
14'-0"	3-1/2"	11-7/8"	14"	14"	14"	14"	14"	14"	14"	14"	16"	16"	16"
	5-1/4"	11-1/4"	11-1/4"	11-1/4"	11-1/4"	11-7/8"	11-7/8"	11-7/8"	14"	14"	14"	14"	14"
16'-0"	3-1/2"	14"	14"	16"	16"	16"	16"	16"	16"	16"	18"	18"	18"
	5-1/4"	11-7/8"	14"	14"	14"	14"	14"	14"	14"	14"	14"	16"	16"
16'-6"	3-1/2"	14"	16"	16"	16"	16"	16"	-	-	-	-	-	-
	5-1/4"	14"	14"	14"	14"	14"	14"	14"	16"	16"	16"	16"	16"
18'-0"	3-1/2"	16"	16"	18"	18"	18"	18"	18"	18"	18"	-	-	-
	5-1/4"	14"	14"	14"	16"	16"	16"	16"	16"	16"	16"	18"	18"
18'-6"	3-1/2"	16"	18"	18"	18"	18"	-	-	-	-	-	-	-
	5-1/4"	14"	14"	16"	16"	16"	16"	16"	16"	16"	18"	18"	18"
20'-0"	3-1/2"	18"	18"	18"	-	-	-	-	-	-	-	-	-
	5-1/4"	16"	16"	16"	16"	18"	18"	18"	18"	18"	18"	18"	-
22'-0"	3-1/2"	-	-	-	-	-	-	-	-	-	-	-	-
	5-1/4"	18"	18"	18"	18"	18"	-	-	-	-	-	-	-
24'-0"	3-1/2"	-	-	-	-	-	-	-	-	-	-	-	-
	5-1/4"	18"	-	-	-	-	-	-	-	-	-	-	-

Span	Beam Width	Span Carried By Beam											
		20'	22'	24'	26'	28'	30'	32'	34'	36'	38'	40'	
6'-0"	3-1/2"	7-1/4"	7-1/4"	7-1/4"	7-1/4"	7-1/4"	7-1/4"	7-1/4"	7-1/4"	7-1/4"	7-1/4"	7-1/4"	7-1/4"
	5-1/4"	7-1/4"	7-1/4"	7-1/4"	7-1/4"	7-1/4"	7-1/4"	7-1/4"	7-1/4"	7-1/4"	7-1/4"	7-1/4"	7-1/4"
8'-0"	3-1/2"	9-1/4"	9-1/4"	9-1/4"	9-1/4"	9-1/4"	9-1/4"	9-1/4"	9-1/4"	9-1/4"	9-1/4"	9-1/4"	9-1/4"
	5-1/4"	7-1/4"	7-1/4"	7-1/4"	7-1/4"	7-1/4"	7-1/4"	7-1/4"	9-1/4"	9-1/4"	9-1/4"	9-1/4"	9-1/4"
9'-6"	3-1/2"	9-1/4"	9-1/4"	9-1/4"	9-1/2"	11-1/4"	11-1/4"	11-1/4"	11-1/4"	11-1/4"	11-1/4"	11-1/4"	11-1/4"
	5-1/4"	9-1/4"	9-1/4"	9-1/4"	9-1/4"	9-1/4"	9-1/4"	9-1/4"	9-1/4"	9-1/4"	9-1/4"	9-1/4"	9-1/2"
10'-0"	3-1/2"	9-1/4"	9-1/2"	11-1/4"	11-1/4"	11-1/4"	11-1/4"	11-1/4"	11-1/4"	11-1/4"	11-1/4"	11-1/4"	11-7/8"
	5-1/4"	9-1/4"	9-1/4"	9-1/4"	9-1/4"	9-1/4"	9-1/4"	9-1/4"	9-1/2"	9-1/2"	11-1/4"	11-1/4"	11-1/4"
12'-0"	3-1/2"	11-1/4"	11-1/4"	11-7/8"	11-7/8"	14"	14"	14"	14"	14"	14"	14"	14"
	5-1/4"	9-1/2"	11-1/4"	11-1/4"	11-1/4"	11-1/4"	11-1/4"	11-1/4"	11-1/4"	11-7/8"	11-7/8"	11-7/8"	11-7/8"
14'-0"	3-1/2"	14"	14"	14"	14"	16"	16"	16"	16"	16"	16"	16"	16"
	5-1/4"	11-1/4"	11-7/8"	11-7/8"	14"	14"	14"	14"	14"	14"	14"	14"	14"
16'-0"	3-1/2"	16"	16"	16"	16"	18"	18"	18"	18"	18"	18"	18"	-
	5-1/4"	14"	14"	14"	14"	14"	16"	16"	16"	16"	16"	16"	16"
16'-6"	3-1/2"	16"	16"	16"	-	-	-	-	-	-	-	-	-
	5-1/4"	14"	14"	14"	16"	16"	16"	16"	16"	16"	16"	16"	16"
18'-0"	3-1/2"	18"	18"	18"	18"	-	-	-	-	-	-	-	-
	5-1/4"	16"	16"	16"	16"	16"	18"	18"	18"	18"	18"	18"	18"
18'-6"	3-1/2"	18"	-	-	-	-	-	-	-	-	-	-	-
	5-1/4"	16"	16"	16"	16"	18"	18"	18"	18"	18"	18"	18"	18"
20'-0"	3-1/2"	-	-	-	-	-	-	-	-	-	-	-	-
	5-1/4"	16"	18"	18"	18"	18"	18"	18"	-	-	-	-	-
22'-0"	3-1/2"	-	-	-	-	-	-	-	-	-	-	-	-
	5-1/4"	18"	18"	-	-	-	-	-	-	-	-	-	-
24'-0"	3-1/2"	-	-	-	-	-	-	-	-	-	-	-	-
	5-1/4"	-	-	-	-	-	-	-	-	-	-	-	-

NOTES:

1. Span is center-to-center of supports and is valid for simple beam spans only.
2. End supports require 3" bearing except 4-1/2" is required where **bold**.
The end supports for the standard garage door spans of 9'-6", 16'-6" and 18'-6" are limited to 3" (two trimmers) on each end.
The bearing length is based on the compressive resistance, perpendicular-to-grain, of the LVL. See the Factored Reaction Resistance table on page 4 for additional information.
3. Deflections are limited to L/360 live/snow load and L/240 total load.
4. Loads assume a 2' maximum overhang on the roof.
5. Beam width can be either a single piece of LVL or built up from multiple plies that are nailed, bolted or connected with other approved fasteners.
Refer to pages 14-15 for connection details.
6. Do not use where marked "-".

Uniform Floor Load (PLF) Tables: 1-3/4"

TO USE:

- Select the span required.
- Divide the design loads by the number of plies to verify each ply of the member. Divide the design loads by 2 to verify a 3-1/2" width or by 3 to verify a 5-1/4" width.
- Compare the factored design total load to the Factored Total Resistance column.
- Compare the unfactored design total load to the Total Load Deflection Resistance.
- Compare the unfactored design live load to the Live Load Deflection Resistance for the appropriate deflection limit.
- Select a product that satisfies all three conditions.

EXAMPLE:

For a 16' beam span, select a 2- and 3-ply beam that satisfies an L/360 Live Load deflection limit for the following specified loads: Live Load = 480 plf; Dead Load = 180 plf

CALCULATE DESIGN LOADS:

Factored Total Load = $(1.5 \times 480) + (1.25 \times 180) = 945$ plf
 Unfactored Total Load = $480 + 180 = 660$ plf

SOLUTION FOR A 2-PLY BEAM:

Factored Total Load per ply = $945/2 = 473$ plf
 Unfactored Total Load per ply = $660/2 = 330$ plf
 Unfactored Live Load per ply = $480/2 = 240$ plf
Use 2 plies 1-3/4" x 14"

SOLUTION FOR A 3-PLY BEAM:

Factored Total Load per ply = $945/3 = 315$ plf
 Unfactored Total Load per ply = $660/3 = 220$ plf
 Unfactored Live Load per ply = $480/3 = 160$ plf
Use 2 plies 1-3/4" x 11-7/8"

Span	1-3/4" x 7-1/4"				1-3/4" x 9-1/4"				1-3/4" x 9-1/2"				1-3/4" x 11-1/4"				Span			
	Unfactored Defl. Resistance			Factored Total Resistance	Unfactored Defl. Resistance			Factored Total Resistance	Unfactored Defl. Resistance			Factored Total Resistance	Unfactored Defl. Resistance			Factored Total Resistance				
	Live Load		Total Load		Live Load		Total Load		Live Load		Total Load		Live Load		Total Load			Live Load		Total Load
	L/480	L/360	L/240		L/480	L/360	L/240		L/480	L/360	L/240		L/480	L/360	L/240			L/480	L/360	L/240
6'	494	659	985	1071	947	1263		1366	1014	1353		1403	1553		1662	6'				
7'	323	430	642	917	630	840		1170	677	902		1202	1054	1406	1423	7'				
8'	221	295	439	802	438	584	872	1023	471	628	938	1051	744	992	1245	8'				
9'	158	211	313	639	316	421	627	909	340	454	676	933	542	723	1079	1105	9'			
10'	116	155	230	516	235	313	465	817	253	337	502	839	406	542	807	994	10'			
11'	88	118	173	426	179	238	353	676	193	257	381	711	311	415	618	903	11'			
12'	68	91	133	357	139	186	274	567	150	200	296	597	244	325	482	823	12'			
13'	54	72	105	303	110	147	216	482	119	159	234	508	194	259	383	700	13'			
14'	43	58	83	261	89	119	173	415	96	128	188	437	157	209	309	602	14'			
15'	35	47	67	227	73	97	141	361	78	105	153	380	128	171	252	524	15'			
16'	-	-	-	-	60	80	116	316	65	87	125	333	107	142	208	459	16'			
17'	-	-	-	-	50	67	96	280	54	72	104	294	89	119	173	406	17'			
18'	-	-	-	-	42	57	80	249	46	61	87	262	75	101	146	361	18'			
19'	-	-	-	-	36	48	68	223	39	52	74	234	64	86	124	324	19'			
20'	-	-	-	-	31	41	58	200	33	45	63	211	55	74	105	291	20'			
21'	-	-	-	-	-	-	-	-	-	-	-	-	48	64	91	264	21'			
22'	-	-	-	-	-	-	-	-	-	-	-	-	42	56	78	239	22'			

Span	1-3/4" x 11-7/8"				1-3/4" x 14"				1-3/4" x 16"				1-3/4" x 18"				Span			
	Unfactored Defl. Resistance			Factored Total Resistance	Unfactored Defl. Resistance			Factored Total Resistance	Unfactored Defl. Resistance			Factored Total Resistance	Unfactored Defl. Resistance			Factored Total Resistance				
	Live Load		Total Load		Live Load		Total Load		Live Load		Total Load		Live Load		Total Load			Live Load		Total Load
	L/480	L/360	L/240		L/480	L/360	L/240		L/480	L/360	L/240		L/480	L/360	L/240			L/480	L/360	L/240
10'	471	628	937	1049	735	980		1237	1042	1390		1414	1404		1591	10'				
11'	362	483	719	953	569	759		1124	813	1084		1285	1104		1445	11'				
12'	284	379	562	873	449	599	891	1030	645	860		1177	882	1176	1324	12'				
13'	226	302	447	776	360	480	713	950	520	693	1032	1085	714	952	1221	13'				
14'	183	244	361	668	292	390	578	881	424	566	841	1007	585	780	1133	14'				
15'	150	200	295	581	241	321	475	790	350	467	693	939	485	647	961	1057	15'			
16'	125	166	244	509	200	267	394	693	292	390	577	880	406	542	804	990	16'			
17'	104	139	204	450	168	225	330	613	246	329	485	787	343	458	678	931	17'			
18'	88	118	171	401	143	190	279	546	209	279	411	701	292	390	576	873	18'			
19'	75	101	145	359	122	163	238	489	179	239	351	628	251	335	493	783	19'			
20'	65	87	124	323	105	140	204	440	155	207	302	566	217	289	425	705	20'			
21'	56	75	107	292	91	122	176	398	134	179	261	512	189	252	369	638	21'			
22'	49	65	92	266	80	106	153	362	118	157	227	466	165	220	322	581	22'			
23'	43	57	80	242	70	93	133	331	103	138	199	425	145	194	282	530	23'			
24'	38	51	70	222	62	82	117	303	91	122	175	390	128	171	248	486	24'			
25'	33	45	61	204	55	73	103	278	81	108	154	358	114	152	220	447	25'			
26'	30	40	54	188	49	65	91	257	72	96	137	330	102	136	195	412	26'			
27'	-	-	-	-	43	58	80	237	65	86	121	306	91	122	174	382	27'			
28'	-	-	-	-	39	52	71	220	58	77	108	283	82	109	155	354	28'			
29'	-	-	-	-	35	47	64	205	52	70	97	263	74	99	139	329	29'			
30'	-	-	-	-	32	42	57	191	47	63	87	246	67	89	125	307	30'			

DESIGN ASSUMPTIONS:

- Span is the center-to-center distance of the supports and is valid for simple or equal, continuous span applications.
- The values in the tables are for uniform loads only.
- Factored Total Resistance is for standard (100%) duration and is adjusted to account for the self-weight of the member. The specified dead load shall not exceed the specified live load.
- Live Load Deflection Resistance is limited to L/360 or L/480 as noted in the table. Vibration has not been considered.
- Total Deflection Resistance is limited to L/240. Long term deflection (creep) has not been considered.
- These tables assume full lateral support of the compression edge. In lieu of a lateral stability analysis: Members with a depth-to-width ratio not exceeding 6.5:1 shall be considered to have full lateral support by direct connection, to the compression edge of the member, of structural wood panel sheathing or by joists spaced not more than 24" oc. Members with a depth-to-width ratio not exceeding 7.5:1 shall also have adequate bridging or blocking installed at an interval not to exceed 8 times the depth of the member. Members with a depth-to-width ratio not exceeding 9:1 shall have both edges supported. Other conditions require further analysis by a design professional.
- Proper bearing must be provided. Bearing length must be checked for support reactions with the table on page 4.

ACTUAL DEFLECTION BASED ON SPAN AND LIMIT

Span (ft)	L/480	L/360	L/240
10'	1/4"	5/16"	1/2"
12'	5/16"	3/8"	5/8"
14'	3/8"	7/16"	11/16"
16'	3/8"	9/16"	13/16"
18'	7/16"	5/8"	7/8"
20'	1/2"	11/16"	1"
22'	9/16"	3/4"	1-1/8"
24'	5/8"	13/16"	1-3/16"
26'	5/8"	7/8"	1-5/16"
28'	11/16"	15/16"	1-3/8"
30'	3/4"	1"	1-1/2"

* Deflections rounded to the nearest 1/16".

ADDITIONAL NOTES:

- The tabulated resistances represent the capacity of the member in pounds per lineal foot (plf) of length.
- The designer shall check the Factored Total Resistance, the Total Deflection Resistance and the appropriate Live Load Deflection Resistance columns.
- Where the Deflection Resistance is blank, the Factored Total Resistance governs the design.
- For 1-3/4" thick LVL, depths of 16" and greater shall be used with a minimum of two plies unless designed specifically as a single ply with proper lateral bracing, such as a marriage beam for each half of a manufactured home before the units are joined.
- The tabulated resistances in the tables are for a single ply of 1-3/4" LVL. For a 3-1/2" wide member, divide the design loads by 2 to verify the resistance of each ply. For a 5-1/4" wide member, divide the design loads by 3.
- The member width shall be properly built up by connecting plies of the same grade of LVL. Refer to the multiple-ply connections on pages 14-15.
- Do not use a product where designated "-" without further analysis by a design professional.

Temporary Bracing & Warnings

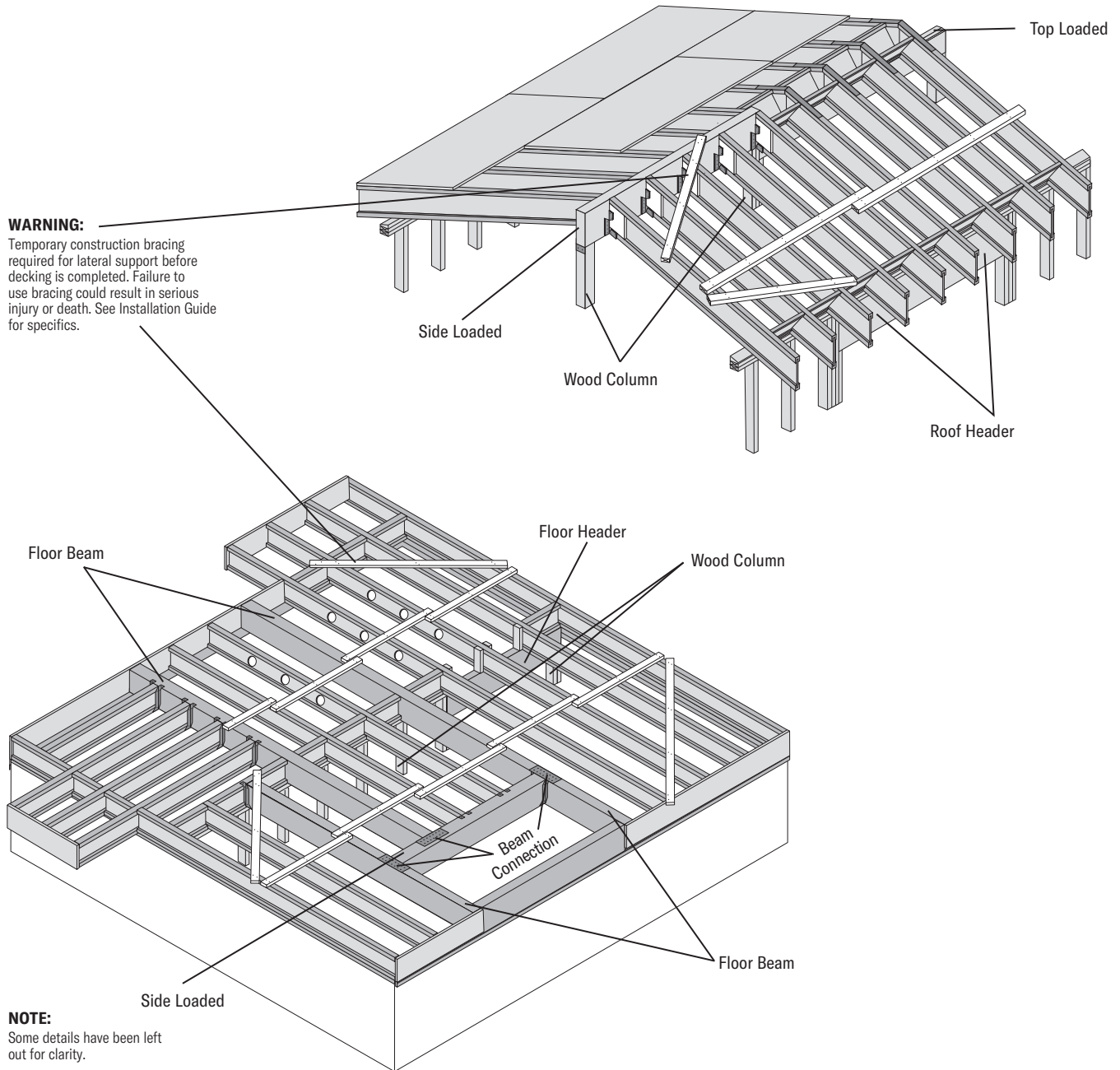

WARNING

The following conditions are NOT permitted!

DO NOT USE VISUALLY DAMAGED PRODUCTS WITHOUT FIRST CHECKING WITH YOUR LOCAL LP SOLIDSTART ENGINEERED WOOD PRODUCTS DISTRIBUTOR OR SALES OFFICE. (SEE BACK COVER FOR DETAILS.)

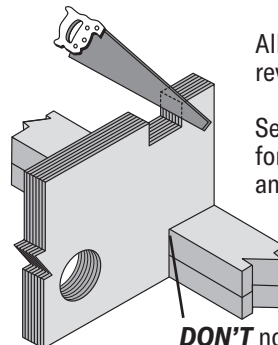

All notched or drilled beams must be reviewed by a professional engineer.

See hole detail on page 13 for allowable hole sizes and locations.

DON'T notch beam at support.

P3 BEAM CONNECTION

Structurally adequate hanger

Hanger shall apply load equally to each ply or special design required

P4 STEEL COLUMN & WOOD COLUMN

Simpson® CCO, USP® CCS or equal column cap

Provide specified bearing length

Framing details such as joists and sheathing shall be provided to prevent beam from twisting or rotating at support

Simpson PC or CC, USP PCM or CC or equal post or column cap

P6 FLOOR BEAM (Flush ceiling)

Top mount hangers recommended

Check stiffener/filler requirements depending on load and hanger type

Prevent the beam from rotating by using rim or blocking

P7 CONCRETE WALL

NOTE: Protect wood from contact with concrete as required by code

Simpson GLB, USP LBS or equal seat

Q1 WINDOW/DOOR HEADER

Rim Board

Provide specified or prescriptive bearing length

Q2 WINDOW/DOOR HEADER

Continuous plate

Provide specified or prescriptive bearing length

BEAM HOLE DETAILS

1 foot

Minimum 2 x diameter of larger hole

1 foot

1/3 beam depth

Area B

Area A

Area B

1/3 span length

Clear span

Q4 MASONRY HANGER

Simpson WM, USP MPH, or equal hanger

NOTE: Protect wood from contact with concrete as required by code

NOTES:

1. These guidelines apply to uniformly loaded beams selected from the Quick Reference Tables or the Uniform Load Tables or designed with LP's design/specification software only. For all other applications, such as beams with concentrated loads, please contact your LP SolidStart Engineered Wood Products distributor for assistance.
2. Round holes can be drilled anywhere in "Area A" provided that: no more than four holes are cut, with the minimum spacing described in the diagram. The maximum hole size is 1-1/2" for depths up to 9-1/4", and 2" for depths greater than 9-1/4".
3. Rectangular holes are NOT allowed.
4. DO NOT drill holes in cantilevers without prior approval from the project designer.
5. Other hole sizes and configurations MAY be possible with further engineering analysis. For more information, contact your LP SolidStart Engineered Wood Products distributor.
6. Up to three 3/4" holes may be drilled in "Area B" to accommodate wiring and/or water lines. These holes shall be at least 12" apart. The holes shall be located in the middle third of the depth, or a minimum of 3" from the bottom and top of the beam. For beams shallower than 9-1/4", locate holes at mid-depth.
7. Protect plumbing holes from moisture.

Connection of Multiple Ply Beams

P1 TOP-LOADED BEAM – NAILED CONNECTION
(See Connection Assemblies for more details)

Minimum nail sizes:
1-3/4" & 2" plies – 16d box (3.5" x 0.135"Ø)
1-1/2" plies – 10d box (3" x 0.128"Ø)

12" oc

Min. 2 rows for depths up to 12"
Min. 3 rows for depths up to 18"
Min. 4 rows for depths greater than 18"
Framing is applied to top of the beam so that each ply carries an equal load

P2 TOP-LOADED BEAM – BOLTED CONNECTION
(See Connection Assemblies for more details)

Framing is applied to top of the beam so that each ply carries an equal load

Nails are permissible but NOT required. See notes for Connection Assemblies.

3"

3"

1/2" diameter ASTM grade A-307 (or better) bolts. Use washers on both faces.

2'-0"

Q3 SIDE-LOADED BEAM
(See Connection Assemblies for more details)

Framing is applied to sides of the beam

SIDE LOADS ARE NOT RECOMMENDED FOR BEAMS OVER 5-1/2" WIDE UNLESS EQUALLY APPLIED TO BOTH FACES
See Connection Assemblies for more information

DETAIL A	DETAIL B	DETAIL C/E	DETAIL D	DETAIL F	DETAIL G	DETAIL H	CONNECTION ASSEMBLIES
MAXIMUM 4" WIDE 2-PLY BEAMS <p>2" max. ply thickness</p>	MAXIMUM 6" WIDE 3-PLY BEAMS <p>2" max. ply thickness</p>	MAXIMUM 7-1/4" WIDE 2-PLY BEAMS <p>2" maximum side member 3-1/2" main member for C 5-1/4" main member for E</p>	MAXIMUM 9-1/4" WIDE 3-PLY BEAMS <p>2" maximum side members 5-1/4" maximum main member</p>	MAXIMUM 7" WIDE 3- OR 4-PLY BEAMS 	MAXIMUM 7" WIDE 2-PLY BEAMS 	MAXIMUM 7" WIDE 2-, 3- OR 4-PLY BEAMS <p>Simpson SDS 1/4" x 6" Simpson SDW 6-3/4" or equal Simpson SDW may be driven from one side.</p>	

* Minimum of 2" or the screw mfg's edge distance.

FACTORED UNIFORM SIDE-LOAD RESISTANCE (PLF)				
Connection Detail	2 Rows of Nails at 12" oc	3 Rows of Nails at 12" oc	2 Rows of 1/2" Bolts at 24" oc	2 Rows of 1/2" Bolts at 12" oc
A	788	1182	780	1560
B	591	887	585	1170
C	591	887	878	1755
D	525	788	780	1560
E	525	788	868	1736
F	na	na	520	1040
G	na	na	1560	3120
H	Refer to Simpson Strong-Tie® catalog for SDS & SDW installation requirements & capacities.			

NAIL SCHEDULE				
Nail Length (in)	Nail Diameter (in)	Factored Lateral Resistance (lbs)	Nail Size Factor	Shank Type
3-1/2"	0.160	216	1.10	common wire
	0.152	197	1.00	spiral
3-1/4"	0.144	178	0.90	common wire
	0.122	131	0.66	spiral
3"	0.120	127	0.64	power-driven ¹³
	0.144	178	0.90	common wire
	0.122	131	0.66	spiral
	0.120	127	0.64	power-driven ¹³

NOTES:

- When driving nails from each face, alternate every other nail in each row.
- Unless specifically designed, use 3-1/2" nails for 1-3/4" thick plies. If the nails do not fully penetrate the second ply (main member), then the nails shall be driven from both faces.
- Use 2 rows of nails for depths to 12". Use 3 rows of nails for depths greater than 12", up to 18". Use 4 rows of nails for depths greater than 18", up to 24".
- Factored resistances are for standard load duration and shall be adjusted according to code. If the dead load exceeds the live load, the appropriate load duration factor (<1) shall be applied.
- The Factored Uniform Side-Load Resistance values are the maximum factored load that can be applied to either side of the beam, based on the selected connection detail, and represent loads applied uniformly such as joists supported by hangers spaced 24" oc or less. Connections for discrete point loads may be determined with this table by calculating the equivalent fastener schedule within a 2' length centered about the point load. Details **B** and **D** shall have the back ply connected with a number of nails equal to half that used to connect the front ply — see the Side-Load Connection Example and detail on page 15. All nail and bolt spacing requirements shall be verified. The full length of the beam shall be connected with the standard connection or with the appropriate side-load connection from this table. The beam shall be designed to support all applied loads.
- The Factored Uniform Side-Load Resistance for nails is based on 3-1/2" spiral nails for 1-3/4" LVL. For other nail sizes, multiply the Factored Uniform Side-Load Resistance by the Nail Size Factor from the Nail Schedule.
- The Factored Uniform Side-Load Resistance for bolts is based on ASTM grade A-307, 1/2"Ø bolts, for loads applied perpendicular-to-grain (see Fastener Design on page 15).
- For nails at 8" oc, multiply resistance by 1.5. For nails at 6" oc, multiply resistance by 2. For four rows of nails, double the two-row resistance.
- For detail **A**, or when attaching the first two plies for detail **B** (and optionally for details **F** and **H** — see note 11), the nails may be driven all from one face or alternating from both faces. If the nails do not fully penetrate the second ply, then the nails shall be driven from both faces.
- For details **C** and **E**, when side-loaded, the larger side-load shall be applied to the thicker ply (main member).
- For details **F** and **H**, it is permissible to nail the plies together before bolting or driving Simpson SDS or SDW (or equal) screws. Nail two plies together (see note 8) then nail one additional ply to each side.
- Beams wider than 5-1/2" shall be top-loaded or side-loaded from both sides to prevent rotation. For side loads applied to one side of a beam only, the project designer shall verify torsional capacity or detail the beam to prevent rotation due to any side loads. Consult a design professional for other options.
- Power-driven nails shall have a yield strength equivalent to common wire nails of the same shank diameter.
- Other nail, screw or bolt configurations are possible. Refer to the Fastener Design table on page 15 or contact your LP SolidStart Engineered Wood Products distributor.

Fastener Design and Fastener & Load Orientation

FASTENER DESIGN

Equivalent Specific Gravity					
Nails Only		Nails and Wood Screws		Bolts and Lag Screws	
Withdrawal		Dowel Bearing		Dowel Bearing (into the face only)	
Edge	Face	Edge	Face	Load Applied Parallel to Grain	Load Applied Perpendicular to Grain
0.46	0.50	0.50	0.50	0.46	0.50

NOTES:

- The equivalent specific gravity for each connection type listed above is for standard load duration and shall be adjusted according to code.
- Fastener spacing, end and edge distance shall be as specified by code except for nail spacing as specified below.
- See details to right for fastener and applied load orientation.

FASTENER & LOAD ORIENTATION

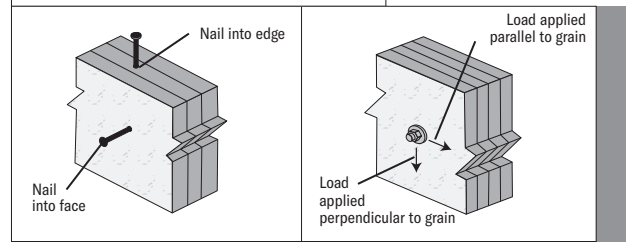

NAIL SPACING REQUIREMENTS

LVL Ply Thickness	Fastener Orientation ⁴	Nail Size ¹ (common wire or spiral)	Minimum End Distance ⁵	Minimum Nail Spacing per Row ⁵	
				Single Row	Multiple Rows ³
≥ 1-1/2"	Edge	2-1/2"	2-1/2"	4"	4" ⁶
		3" & 3-1/4"	2-1/2"	4"	5" ⁶
		3-1/2"	3-1/2"	5"	6" ^{6,7}
	Face	2-1/2"	1-1/2"	3"	3"
		3" & 3-1/4"	1-1/2"	3"	3"
		3-1/2"	1-1/2"	5"	5"

NOTES:

- Nails are common wire or spiral nails in accordance with CSA O86.
- Edge distance shall be such that does not cause splitting.
- Multiple rows of nails shall be offset at least 1/2" and staggered.
- Edge orientation refers to nails driven into the narrow edge of the LVL, parallel to the face of the veneers. Face orientation refers to nails driven into the wide face of the LVL, perpendicular to the face of the veneers. (See Fastener & Load Orientation details above.)
- Minimum End Distance and Minimum Nail Spacing are tabulated based on common wire nails. For nails with smaller diameters, the spacing and end distance of the common wire nail with the next larger diameter may be used.
- Minimum nail spacing is tabulated for LVL stamped with plant number 1089. The minimum spacing may be reduced 1" for LVL stamped with plant numbers 1066 and 1071.
- Minimum nail spacing may be reduced 1" for LVL stamped with plant number 1089, for thickness of 1-3/4" or greater.

SIDE-LOAD CONNECTION EXAMPLE

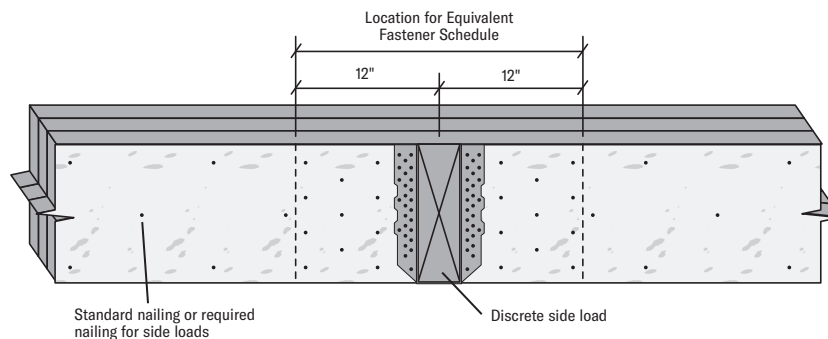

EXAMPLE: Assuming a properly designed 3-ply 14" beam, determine the equivalent connection to support a factored point load of 6970 lb applied to the side of the beam.

SOLUTION:

- Determine the equivalent PLF load over the 2' length by dividing the applied factored load by 2: $6970 \text{ lb} / 2' = 3485 \text{ plf}$.
- Divide the equivalent PLF load by the factored uniform side-load resistance for the appropriate detail. For a 14" depth, 3 rows of nails are required. For detail **B** with 3 rows of 3-1/2" spiral nails at 12" oc: $3485 \text{ plf} / 887 = 3.9$.
- The required total number of nails is: $3.9 * 3 \text{ rows of nails @ } 12" \text{ oc} = 11.7 \text{ nails per foot}$.
- Connect the front (loaded) ply with the nailing determined in step 3: drive 12 3-1/2" spiral nails within 12" to each side of the point load (a total of 24 nails).
Verify nail spacing.
- Connect the back ply with half the number of nails determined in step 4: drive 6 3-1/2" nails, from the back, within 12" to each side of the point load (a total of 12 nails).
Verify nail spacing.
- Connect full length of member with the standard nailing or as required for side loads.
- Project designer shall detail to prevent rotation of the beam due to the applied side load.

HANDLING & STORAGE GUIDELINES

- **WARNING:** Failure to follow proper procedures for handling, storage and installation could result in unsatisfactory performance, unsafe structures and possible collapse.
- Keep LP® SolidStart® LVL dry. These products are intended to resist the effects of moisture on structural performance from normal construction delays but are not intended for permanent exposure to the weather.
- Unload products carefully, by lifting. Support the bundles to reduce excessive bowing. Individual products should be handled in a manner which prevents physical damage during measuring, cutting, erection, etc.
- Keep products stored in wrapped and strapped bundles, stacked no more than 10' high. Support and separate bundles with 2 x 4 (or larger) stickers spaced no more than 10' apart. Keep stickers in line vertically.
- Product must not be stored in contact with the ground, or have prolonged exposure to the weather.
- Use forklifts and cranes carefully to avoid damaging product.
- Do not use a visually damaged product. Call your local LP SolidStart Engineered Wood Products distributor for assistance when damaged products are encountered.
- For satisfactory performance, LP SolidStart LSL and LVL must be used under dry, covered and well-ventilated interior conditions in which the equilibrated moisture content does not exceed a yearly average of 15% and does not exceed 19% at any time.
- For built-up members, LP SolidStart LVL shall be dry before nailing or bolting to avoid trapping moisture.
- LP SolidStart LVL shall not be used for unintended purposes such as ramps and planks.

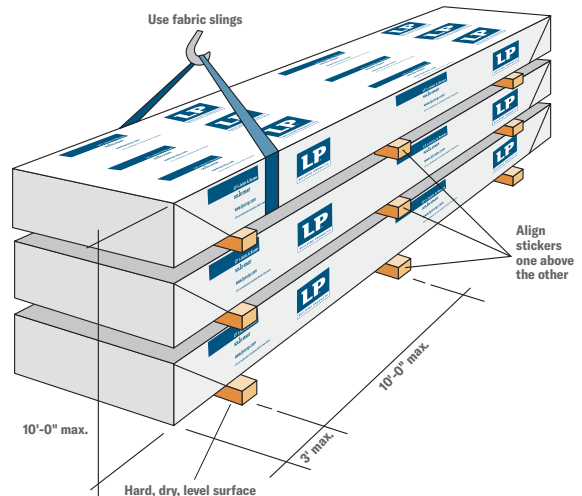

LP SolidStart LVL 2.0E

Standard Thickness of 1-3/4" and 3-1/2" (also available in 1-1/2")
Billet thicknesses of 5-1/4" and 7"

Standard Depths of 7-1/4", 9-1/4", 9-1/2", 11-1/4", 11-7/8", 14", 16", 18", 20", and 24"

Lengths up to 60'

CODE EVALUATION

Code evaluation reports can be obtained at www.lpcorp.com
CCMC 11518-R
APA PR-280C

Specific sizes may not be available in all locations, contact your local distributor for availability.
A water-resistant coating called SiteCote™ is applied to LP LVL for extra weather protection during construction.

For more information on the full line of LP® SolidStart® Engineered Wood Products or the nearest distributor, visit our web site at LPCorp.com.

Phone: 1-888-820-0325
E-mail: customer.support@LPCorp.com.

LP SolidStart Engineered Wood Products are manufactured at different locations in the United States and Canada.
Please verify availability with the LP SolidStart Engineered Wood Products distributor in your area before specifying these products.



Good for you. Good for our forests.
www.sfi-program.org

BV-SFICOC-US09000262



PEFC/29-31-102



For product catalog & complete warranty details, visit LPCorp.com

© 2019 Louisiana-Pacific Corporation. All rights reserved. SIMPSON Strong-Tie® is a registered trademark of Simpson Strong-Tie Company, Inc. USP® is a registered trademark of MiTek Holdings, Inc. SFI and the associated logo are trademarks of Sustainable Forestry Initiative, Inc. PEFC and the associated logo are trademarks of Programme for the Endorsement of Forest Certification. SiteCote™ is a trademark of Louisiana-Pacific Corporation. LP® and SolidStart® are registered trademarks of Louisiana-Pacific Corporation. Printed in USA. Specifications (details) subject to change without notice.

NOTE: Louisiana-Pacific Corporation periodically updates and revises its product information. To verify that this version is current, contact the nearest sales office, visit LPCorp.com, or call 1-888-820-0325.